

SECTION A-A

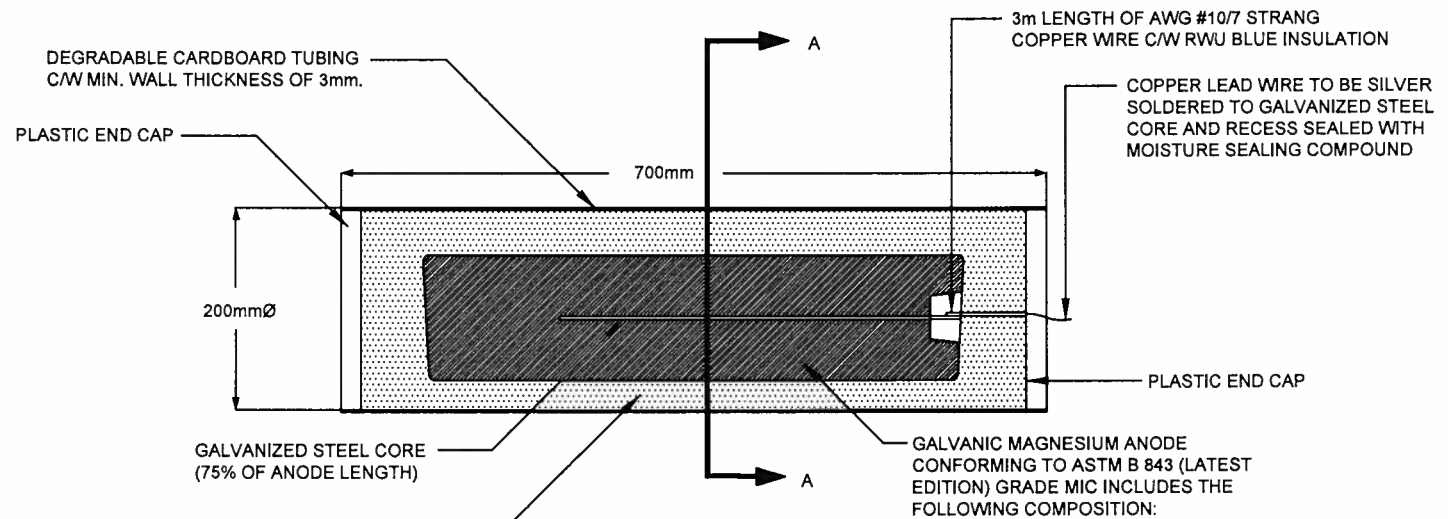

CHEMICAL BACKFILL MIXTURE PER INDUSTRY STANDARD  
LESS THAN 45 OHM-CM RESISTIVITY BACKFILL  
SURROUNDING ANODE COMPRISED OF:

77% +/- 1%	GROUND HYDRATED GYPSUM
15% +/- 1%	POWDERED WYOMING BENTONITE
8% +/- 1%	ANHYDROUS SODIUM SULFATE

ALUMINUM	0.01% MAX.
MANGANESE	0.5% - 1.3% MAX.
SILICON	0.05% MAX.
COPPER	0.02% MAX.
NICKEL	0.001% MAX.
IRON	0.03% MAX.
OTHER METALLIC IMPURITIES (EACH)	0.05% MAX.
OTHER (TOTAL)	0.3% MAX.
MAGNESIUM	REMAINDER