

CROSSING OVER UTILITY

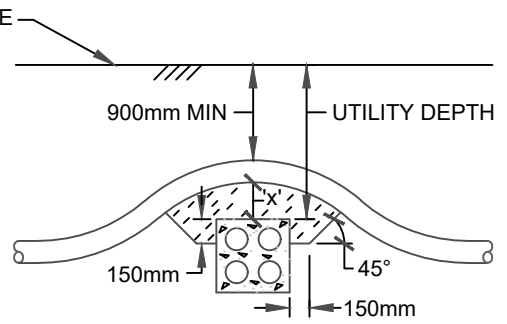

CROSSING OVER CONCRETE ENCASED UTILITY

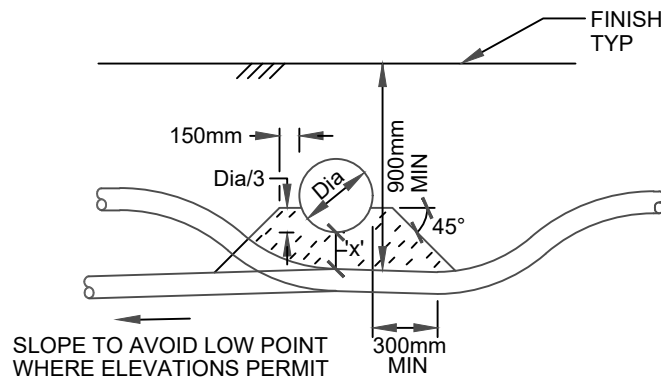

CROSSING UNDER UTILITY

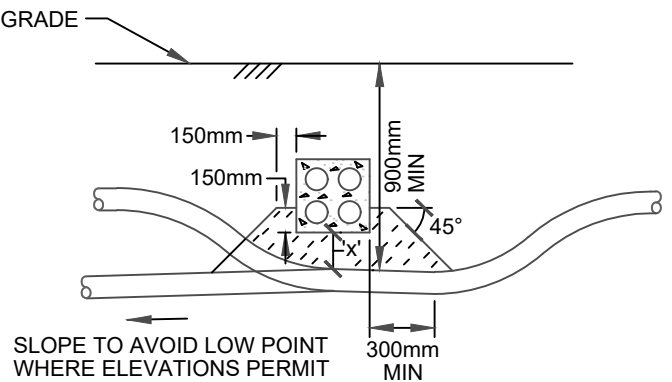

CROSSING UNDER CONCRETE ENCASED UTILITY

NOTES:

1. THE REQUIRED CLEARANCE 'X' BETWEEN THE UTILITY AND THE DUCTS OR CONCRETE ENCASEMENT IS:

| UTILITY                         | 'x' mm MIN |
|---------------------------------|------------|
| DUCTS, DIRECT BURIED OR ENCASED | 100        |
| ALL OTHER PIPES                 | 500        |
| HIGH VOLTAGE CABLES             | 1000       |
| ALL OTHER CABLES                | 300        |

2. TRENCH WIDTHS AS PER OCCUPATIONAL HEALTH AND SAFETY ACT. UTILITY SUPPORTED IN PLACE WHERE REQUIRED.

3. ALL DIMENSIONS ARE IN MILLIMETRES UNLESS OTHERWISE SHOWN.



ROADWAY LIGHTING DUCT UTILITY CROSSING

REV No.

2

DATE: APR 2023

SCALE: N.T.S.

R331