

**AERIAL INSTALLATION**

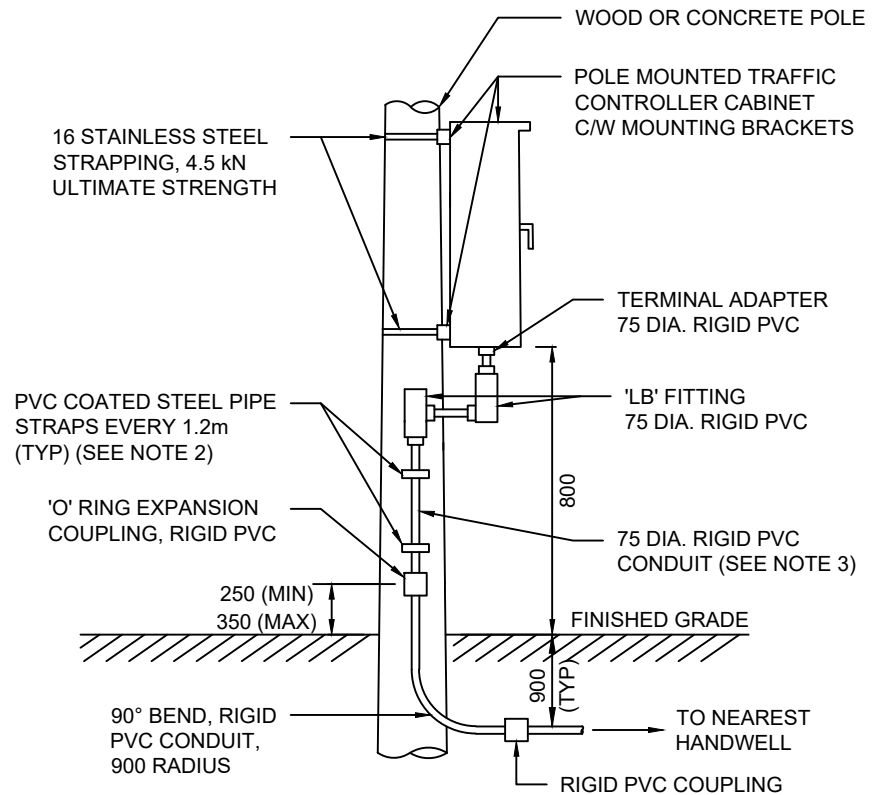

**UNDERGROUND INSTALLATION**

**NOTES:**

1. ALL DIMENSIONS ARE IN MILLIMETERS UNLESS OTHERWISE SHOWN.
2. 16 STAINLESS STEEL BANDING TAPE SHALL BE USED IN LIEU OF PIPE STRAPS ON CONCRETE POLES.
3. CONDUIT SHALL BE PLACED SO THAT HANDHOLES ARE UNOBSTRUCTED ON CONCRETE POLES.
4. FOR TRAFFIC CONTROLLER CABINET MOUNTING DETAILS ON STEEL POLE, SEE BSD R349



**TRAFFIC CONTROLLER CABINET  
WOOD OR CONCRETE POLE**

REV No.	DATE: APR 2023
3	SCALE: N.T.S.

**R350**