

SECTION THROUGH TAPER TOP

ALL JOINTS BETWEEN UNITS ARE TO BE IN ACCORDANCE WITH MANUFACTURERS SPECIFICATIONS AND GUIDELINES WITH APPROPRIATE CAULKING.

THE FIRST ADJUSTMENT UNIT IS TO BE PLACED IN MORTAR (CONFORMING WITH OPS 407.05.06) OR CONCRETE (CONFORMING WITH OPS 407.05.01) (TYPICAL)

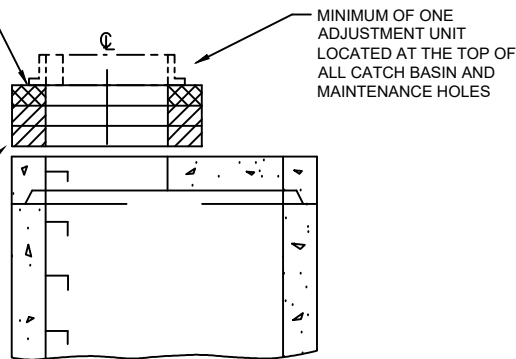

SECTION THROUGH FLAT CAP

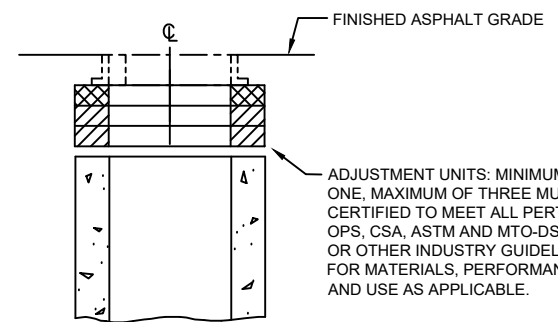

SECTION THROUGH CATCH BASIN

ADJUSTMENT UNITS: MINIMUM OF ONE, MAXIMUM OF THREE MUST BE CERTIFIED TO MEET ALL PERTINENT OPS, CSA, ASTM AND MTO-DSM LIST, OR OTHER INDUSTRY GUIDELINES FOR MATERIALS, PERFORMANCE AND USE AS APPLICABLE.

ADJUSTMENT UNITS FOR MAINTENANCE HOLES WITH ROUND OPENINGS ARE AVAILABLE IN SECTIONS OR CONTINUOUS UNITS.

SELF-LEVELLING FRAME AND GRATE OR COVER SHALL BE USED FOR ALL NEW MAINTENANCE HOLES WITHIN AN ASPHALT ROADWAY

ADJUSTMENT UNITS FOR CATCH BASINS WITH SQUARE OPENINGS ARE AVAILABLE IN SECTIONS OR CONTINUOUS UNITS.

TAPER TOP

FLAT CAP

CATCH BASIN

NOTES:

1. ADJUSTMENT UNITS SHALL NOT EXTEND BEYOND THE OUTSIDE EDGE OF THE STRUCTURE.
2. MAINTENANCE HOLE TOPS (FRAMES) ARE TO BE SET IN BASE ASPHALT GRADE AND THEN ADJUSTED TO FINAL GRADE WHEN TOP LIFT OF ASPHALT IS PLACED.
3. ALL DIMENSIONS ARE IN MILLIMETRES UNLESS OTHERWISE SHOWN.
4. IF A STEP IS REQUIRED IN AN ADJUSTMENT UNIT, THEN THE ADJUSTMENT UNIT SHALL BE OF THE TYPE MANUFACTURED WITH A STEP IN PLACE.



Maintenance Hole and Catch Basin Grade Adjustment

REV No.

5

DATE: APR 2023

SCALE: N.T.S

S606