

AUGURED/VACUUMED HOLE (TO BE VACUUMED WITHIN 300mm FROM TOP OF PIPE)

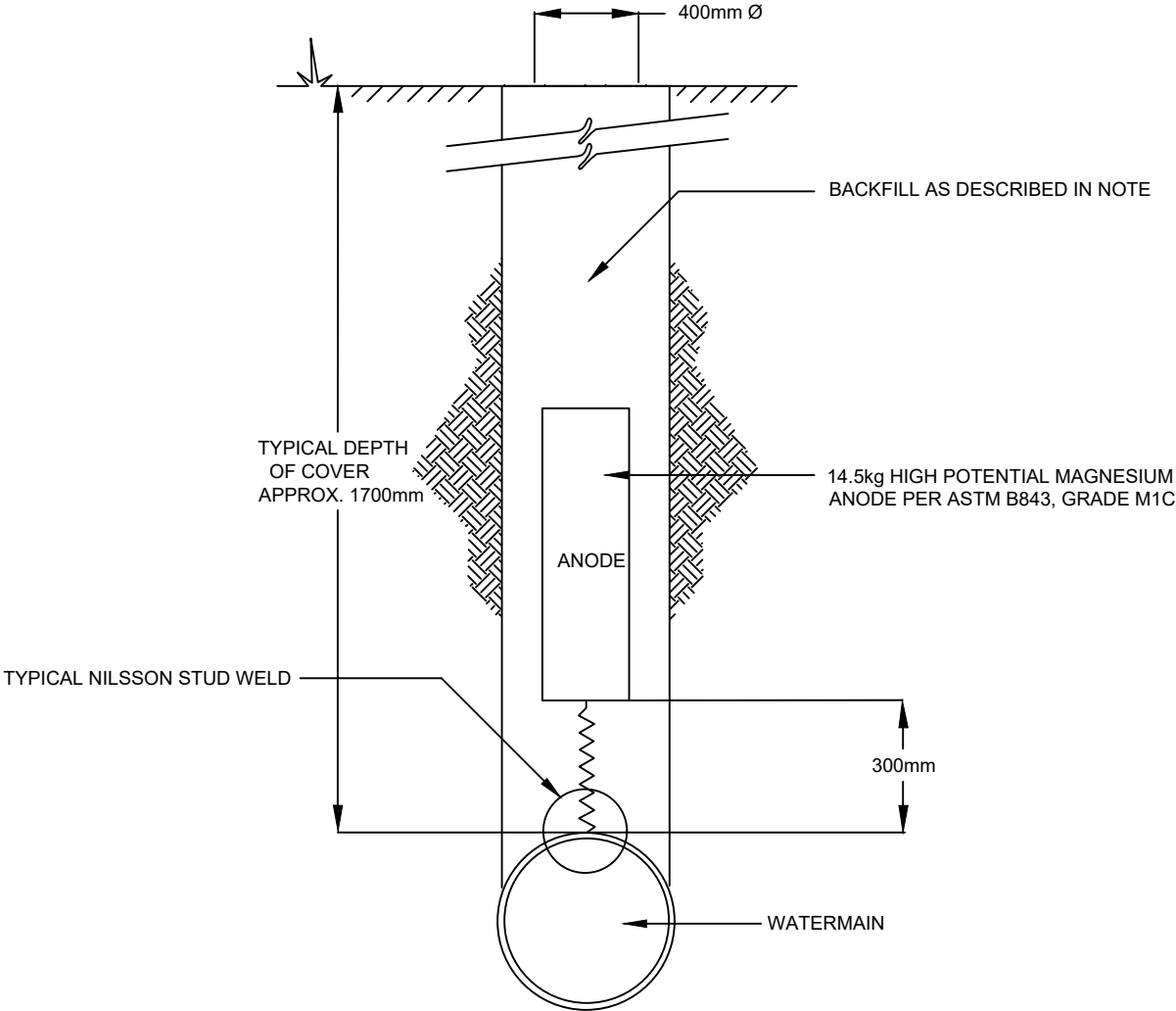

- NOTES:
1. BACKFILL SHALL HAVE A GRAIN SIZE RANGE, 100% PASSING 850um, 50% RETAINED BY 150um SCREEN.
  2. PAVEMENT STRUCTURE TO BE REINSTATED TO MATCH EXISTING.
  3. CLUSTER ANODE INSTALLATIONS REQUIRE ASPHALT LANE PATCHING AT THE CITY'S DISCRETION.



# Anode Installation

REV No. DATE: APR 2023

2

SCALE: N.T.S

W530