

Meter size	"Y"	"X"
38mm (1.5")	330mm (13")	2.5x Pipe dia.
50mm (2")	387mm (15 1/4")	
75mm (3")	432mm (17")	
100mm (4")	508mm (20")	
150mm (6")	610mm (24")	
200mm (8")	765mm (30 1/8")	
250mm (10")	1045mm (41 1/8")	

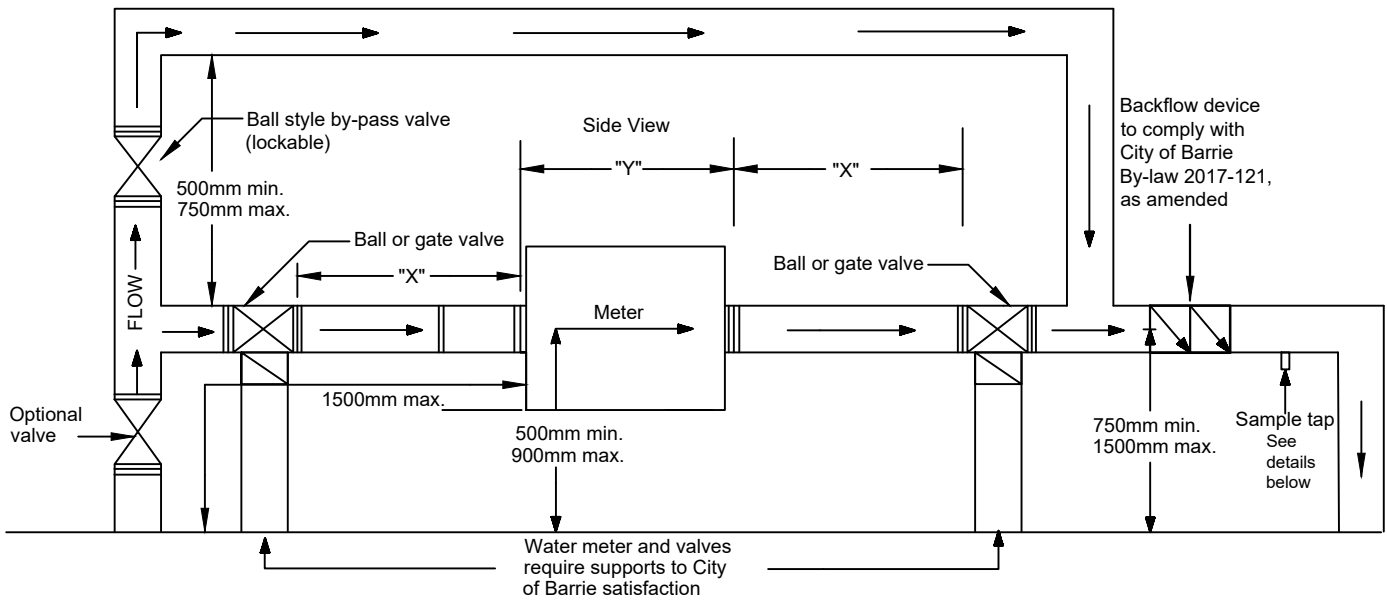

NOTES:

1. The diameter of the by-pass line shall match the diameter of the water meter.
2. All materials to be supplied by the contractor except water meters. All meters larger than 50mm are to be supplied and installed by the contractor.
3. Butterfly valves or globe valves shall not be used.
4. All piping between water service entering the building and backflow device must be labeled 'No connection permitted'.
5. Backflow device must be installed within a maximum of 3 meters downstream of the water meter.
6. Meter wire, installed in conduit, to be run from meter location to outside of building at the direction of the Barrie Water Operations representative. Meter wire (22 gauge, 2 conductor, metgray, UV rated) supplied by the City of Barrie.
7. All dimension are in millimeters unless otherwise shown.
8. Contractor to provide flat secure (vertical) surface for the smart point and lock box to be mounted on.
9. Clearance for backflow device does not apply when installed in an enclosure certified to ASSE 1060. Backflow device must still be accessible for maintenance and testing.
10. Enclosure to contain a heat source to provide protection from freezing conditions.
11. Minimum 600mm pathway from enclosure/structure access to water meter is required.
12. Structure to be protected from vehicular traffic as required by the City of Barrie.

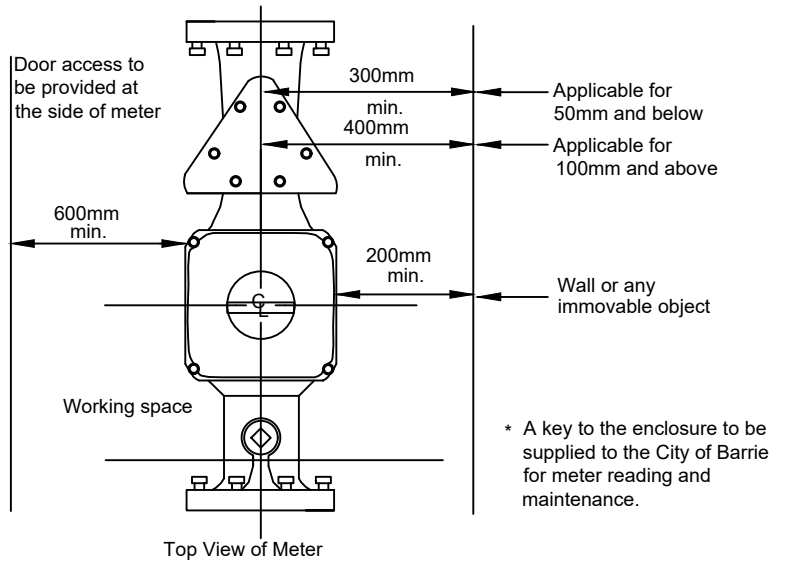
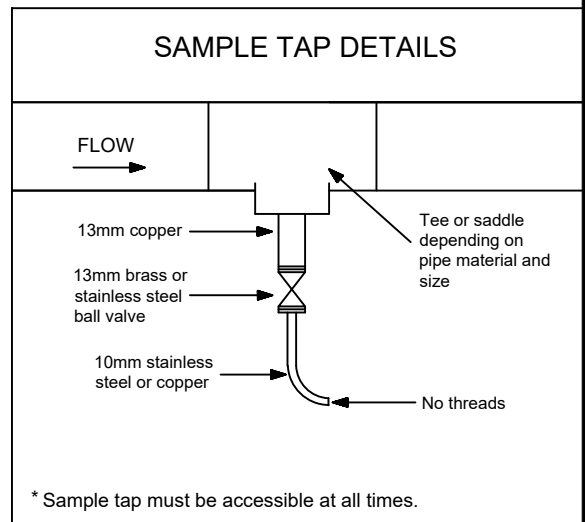

**Water Meter Installation
Bulk Metering Structure**

REV No.
3

DATE: MARCH 2024

SCALE: N.T.S

W536