

435 Anne Street North

City of Barrie

Traffic Brief for Wynstar Anne Street LP Inc.

Type of Document:
Final Report

Project Number:
JDE – 23087

Date Submitted:
January 17th, 2025



John Northcote, P.Eng.
Professional License #: 100124071



Jacob Losole, P.Eng.
Professional License #: 100509766



ENGINEERING

JD Northcote Engineering Inc.
86 Cumberland Street
Barrie, ON
705.725.4035
www.JDEngineering.ca

Legal Notification

This report was prepared by **JD Northcote Engineering Inc.** for the account of **Wynstar Anne Street LP Inc.**

Any use which a third party makes of this report, or any reliance on or decisions to be made based on it, are the responsibility of such third parties. **JD Northcote Engineering Inc.** accepts no responsibility for damages, if any, suffered by any third party as a result of decisions made or actions based on this project.

Table of Contents

1	Introduction.....	1
1.1	Background.....	1
1.2	Study Area	1
1.3	Study Scope and Objectives	2
1.4	Horizon Year and Analysis Periods	3
2	Information Gathering.....	3
2.1	Street and Intersection Characteristics	3
2.2	Local Transportation Infrastructure Improvements.....	4
2.3	Transit Access	5
2.4	Other Developments within the Study Area	6
2.5	Background Traffic Growth.....	6
2.6	Traffic Counts	6
2.7	Existing Traffic Volumes.....	6
2.8	Horizon Year Traffic Volumes.....	6
3	Intersection Operation without Proposed Development.....	9
3.1	Introduction	9
3.2	Existing Intersection Operation.....	10
3.3	Background (2027) Intersection Operation	10
4	Proposed Development Traffic Generation and Assignment.....	11
4.1	Traffic Generation	11
4.2	Traffic Assignment.....	12
4.3	Total Horizon Year Traffic Volumes with the Proposed Development	13
5	Intersection Operation with Proposed Development	15
5.1	Total (2027) Intersection Operation.....	15
5.2	Site Access & Intersection Spacing.....	15
5.3	Sight Distance Review.....	16
5.4	Construction Staging	16
5.5	Swept Path Analysis.....	17
6	Parking Review	17
7	Summary	17

List of Tables

Table 1 – Traffic Count Data	6
Table 2 – Level of Service Criteria for Intersections.....	9
Table 3 – Existing (2024) LOS	10
Table 4 – Background (2027) LOS.....	10
Table 5 – ITE Traffic Generation Trip Rates (Subject Site).....	11
Table 6 – Estimated Trip Generation of the Proposed Development.....	12
Table 7 – Proposed Development Traffic Distribution.....	12
Table 8 – Total (2027) LOS	15
Table 9 – Zoning By-law Parking Requirements	17

List of Figures

Figure 1 – Proposed Site Location and Study Area	2
Figure 2 – Existing (2024) Intersection Spacing and Lane Configuration within Study Area.....	4
Figure 3 – Study Area Transit Routes	5
Figure 4 – Existing (2024) Traffic Volumes	7
Figure 5 – Background (2027) Traffic Volumes.....	8
Figure 6 – Site Traffic Assignment	13
Figure 7 – Total (2027) Traffic Volumes	14

List of Appendices

APPENDIX A – Site Plan
APPENDIX B – Traffic Count Data
APPENDIX C – Synchro Analysis Output – Existing Traffic Volumes
APPENDIX D – Synchro Analysis Output – Background Traffic Volumes
APPENDIX E – Synchro Analysis Output – Total Traffic Volumes
APPENDIX F– Transportation Tomorrow Survey Excerpt
APPENDIX G – MTO Left Turn Warrant Analysis
APPENDIX H– OTM Signal Justification Sheets
APPENDIX I – Swept Analysis

1 Introduction

1.1 Background

Wynstar Anne Street LP Inc. [the Developer] is proposing a development on a site municipally known as 435 Anne Street North, located on the east side of Anne Street North, west of Harrison Crescent, in the City of Barrie [City].

The proposed development includes 84 townhouse units, 8 semi-detached units and 4 single-detached units.

Access to the 84 townhouse units is proposed via two full-movement driveway connections to Anne Street North, [North Access] and [South Access]. Access to the 8 semi-detached units and 4 single-detached units is proposed via private driveway connections to Harrison Crescent.

It is anticipated that build-out will occur by 2027.

The Developer has retained **JD Northcote Engineering Inc.** [JD Engineering] to prepare this traffic brief in support of the proposed development.

1.2 Study Area

Figure 1 shows the location of the subject site and study area intersections in relation to the surrounding area. The Conceptual Site Plan by IPS Innovative Planning Solutions is provided in **Appendix A**.

The subject site is bound by Anne Street North to the west, Harrison Crescent to the east, Enbridge Barrie Gas Station to the north and existing residential area to the south.

Through consultation with the City, the following intersections are included in the traffic brief study:

- Anne Street North / North Access & Neelands Street; and
- Anne Street North / South Access.

Figure 1 – Proposed Site Location and Study Area



1.3 Study Scope and Objectives

The purpose of this study is to identify the potential impacts to traffic flow at the site accesses and on the surrounding roadway network. The study analysis includes the following tasks:

- Consult with the City to address any traffic-related issues or concerns they have with the proposed development;
- Determine existing traffic volumes and circulation patterns;
- Estimate future traffic volumes if the proposed development was not constructed, including the impact of additional proposed developments in the area;
- Complete level-of-service [LOS] analysis of horizon year (without the proposed development) traffic conditions and identify operational deficiencies;
- Estimate the amount of traffic that would be generated by the proposed development and assign to the roadway network;
- Complete LOS analysis of horizon year (with the proposed development) traffic conditions and identify additional operational deficiencies;
- Identify improvement options to address operational deficiencies;
- Review the proposed intersection spacing;
- Review the available sight distance at the proposed site access driveways;
- Prepare a Construction Staging Plan; and
- Document findings and recommendations in a final report.

1.4 Horizon Year and Analysis Periods

Traffic scenarios for the existing year¹ and buildout horizon year (2027) have been selected as the horizon years for this study. The weekday morning [AM] and weekday afternoon [PM] peak hours have been selected as the analysis periods for this study.

2 Information Gathering

2.1 Street and Intersection Characteristics

Anne Street North is a two-lane arterial road within the study area. Anne Street North has an urban cross-section and a sidewalk on the west side of the road within the study area. Anne Street North has a sidewalk on both sides of the road approximately 60 meters south of the South Access. Anne Street North has a posted speed limit of 50km/h within the study area and is under the jurisdiction of the City.

Neelands Street is a two-lane local road with an urban cross-section through the study area and a sidewalk on the north side of the road. Neelands Street has an assumed (unposted) speed limit of 50km/h within the study area and is under the jurisdiction of the City.

Harrison Crescent is a two-lane local road with an urban cross-section through the study area and a sidewalk on the west side of the road. Harrison Crescent has an assumed (unposted) speed limit of 50km/h within the study area and is under the jurisdiction of the City.

The existing intersection spacing and lane configuration within the study area is illustrated in **Figure 2**.

¹ 2024 reflects the existing year at the onset of the project.

Figure 2 – Existing (2024) Intersection Spacing and Lane Configuration within Study Area

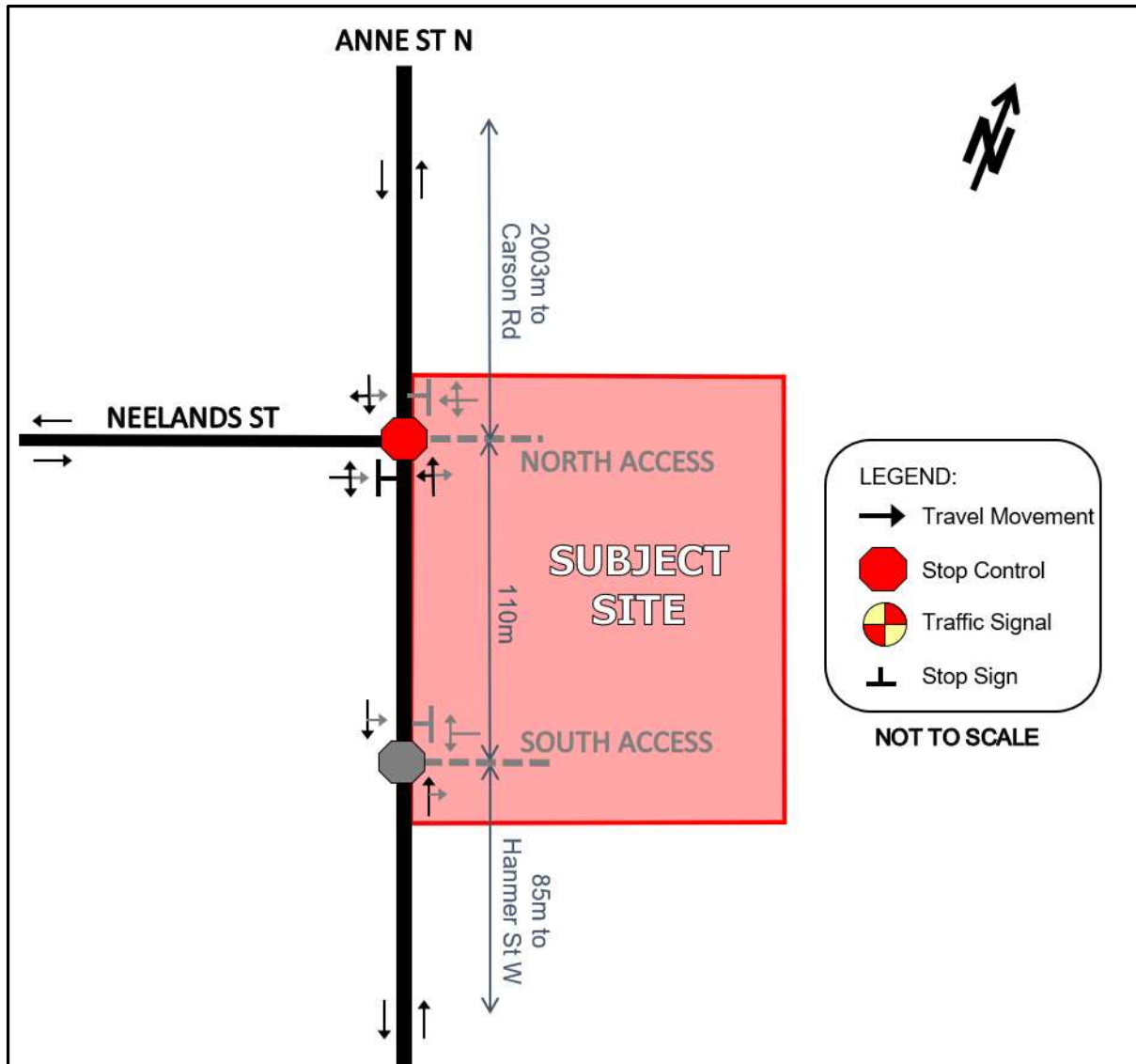

2.2 Local Transportation Infrastructure Improvements

Based on the City's Transportation Master Plan (April 2019) [TMP] and the City's 2024 Capital Plan, the following improvements are anticipated to be completed within the study area:

- Anne Street North
 - Proposed road widening to 3-lanes (2 lanes + a centre two-way left-turn lane), by 2031;
 - Construction of a buffered bike lanes north of Hammer Street South (timeline to be determined); and
 - Construction of a sidewalk on one side of the road north of Hammer Street South (timeline to be determined).

2.3 Transit Access

The City's transit provider, Barrie Transit [BT], provides one bus route within the study area.

The No.6 (6A: Letitia and 6B: College) bus route operates between 05:45 – 24:14 on weekdays with peak hour service every 60 minutes, between 07:15 – 24:11 on Saturdays with service every 30 minutes and between 09:15 – 22:23 on Sundays with service every 60 minutes. The closest bus stop to the proposed development is located at the northeast corner and southwest corner of Livingstone Street West / Anne Street North intersection, approximately 350 metres south of the subject site.

Figure 3 illustrates the transit service within the study area.

Figure 3 – Study Area Transit Routes

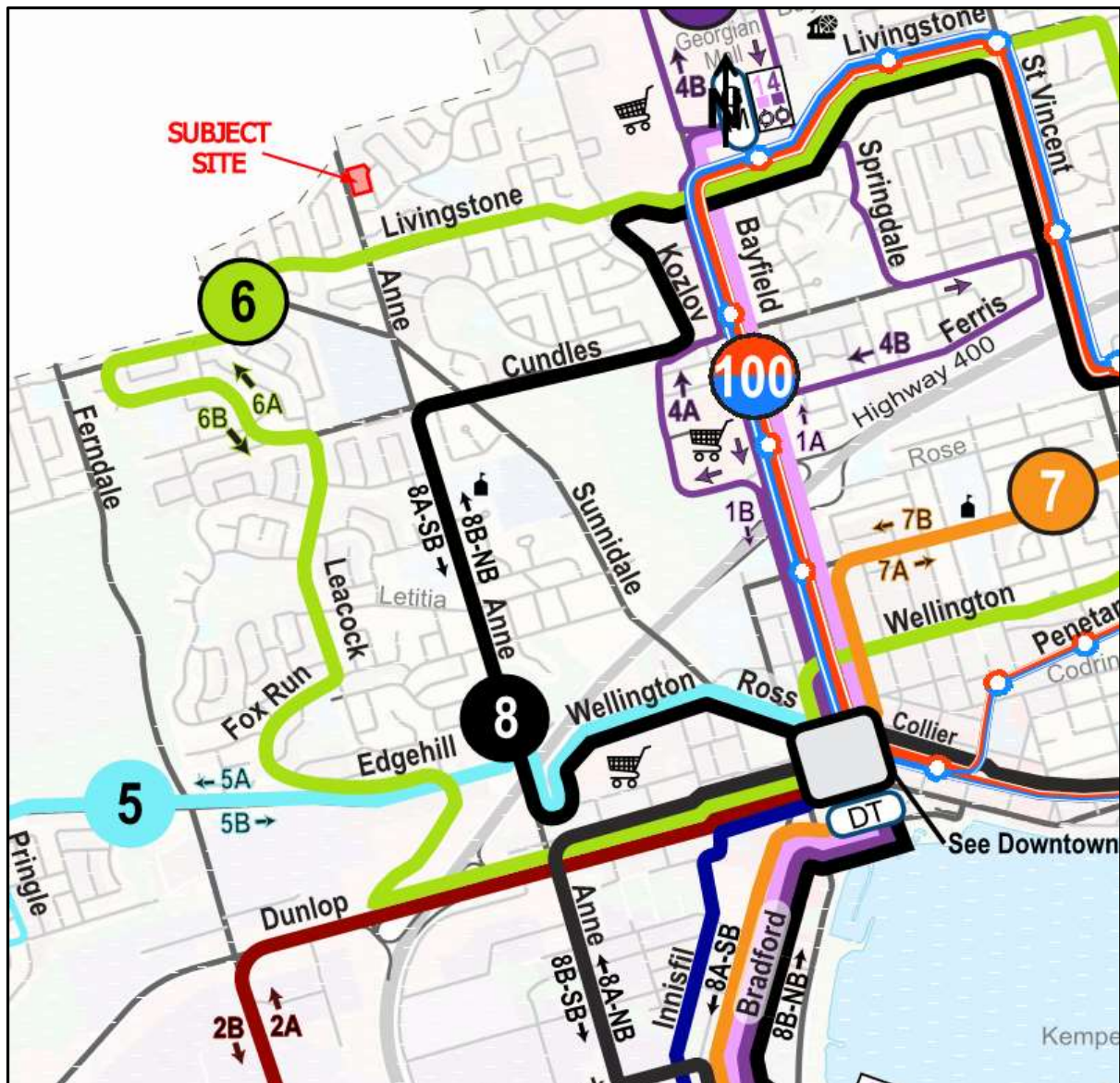

2.4 Other Developments within the Study Area

Based on our review of the City’s Development Project webpage, and our correspondence with City Staff, there are no adjacent developments near the study area that will impact the traffic within the study area.

2.5 Background Traffic Growth

Based on our correspondence with City staff, an industry standard background growth rate of 2% per year has been applied for the study area.

2.6 Traffic Counts

Detailed turning movement traffic and pedestrian counts were commissioned by JD Engineering. **Table 1** summarizes the traffic count data collection information. Detailed traffic count data can be found in **Appendix B**.

Table 1 – Traffic Count Data

Intersection (N-S Street / E-W Street)	Count Date	AM Peak Hour	PM Peak Hour	Source
Anne Street North / Neelands Street	Tuesday April 16, 2024	08:00 – 09:00	16:15 – 17:15	JD Eng.*

*Traffic counts were completed by Ontario Traffic Inc. on behalf of JD Engineering.

Heavy vehicle percentages from the traffic count data have also been included in the Synchro analysis.

2.7 Existing Traffic Volumes

The 2024 existing AM and PM peak hour traffic volumes in the study area are illustrated in **Figure 4**, established based on the conducted counts.

2.8 Horizon Year Traffic Volumes

The background (2027) horizon year traffic volumes are illustrated in **Figure 5**. The background volumes are based on the existing (2024) volumes, adjusted to reflect the annual background growth rate noted in Section 2.5.

Figure 4 – Existing (2024) Traffic Volumes

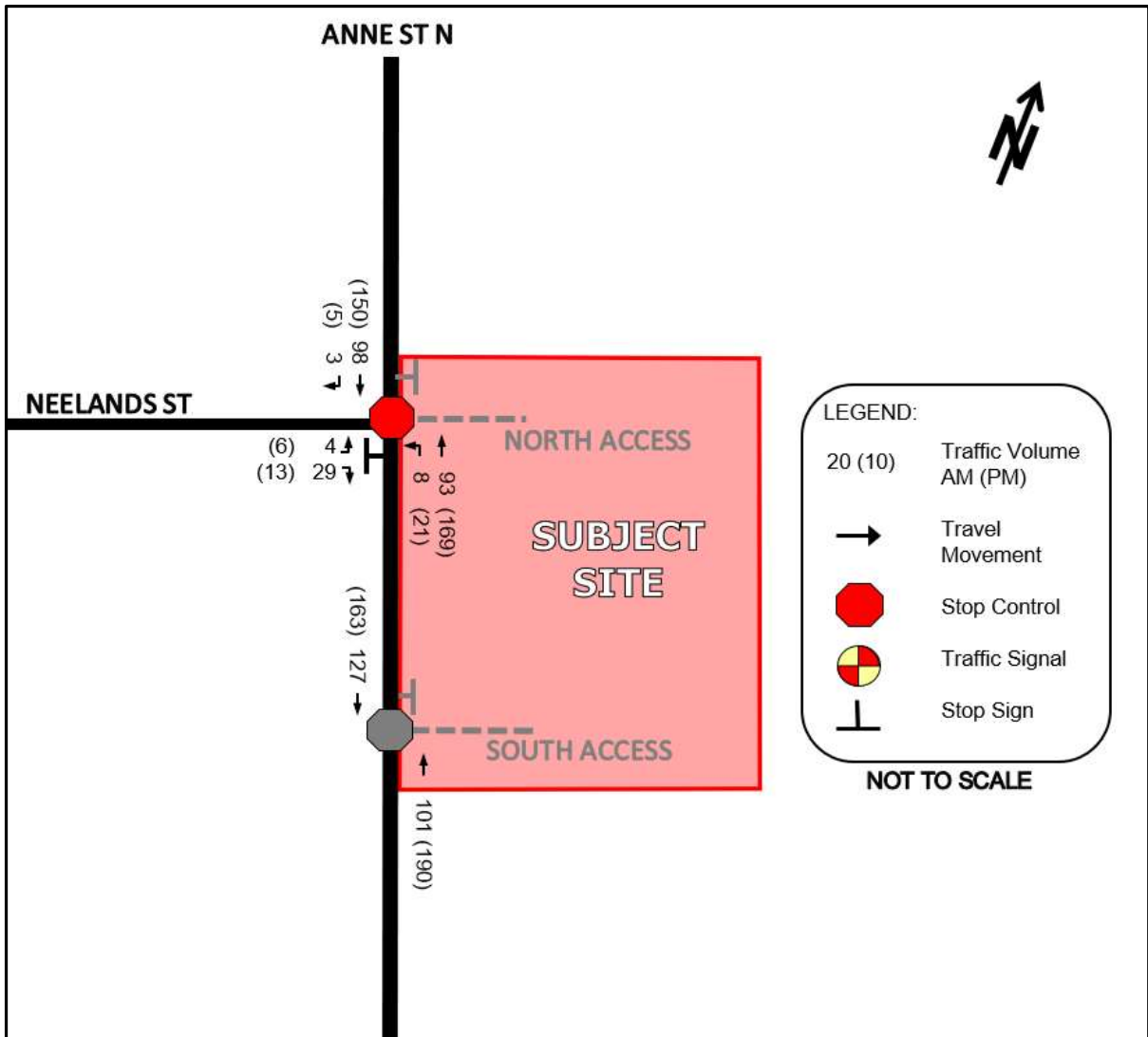
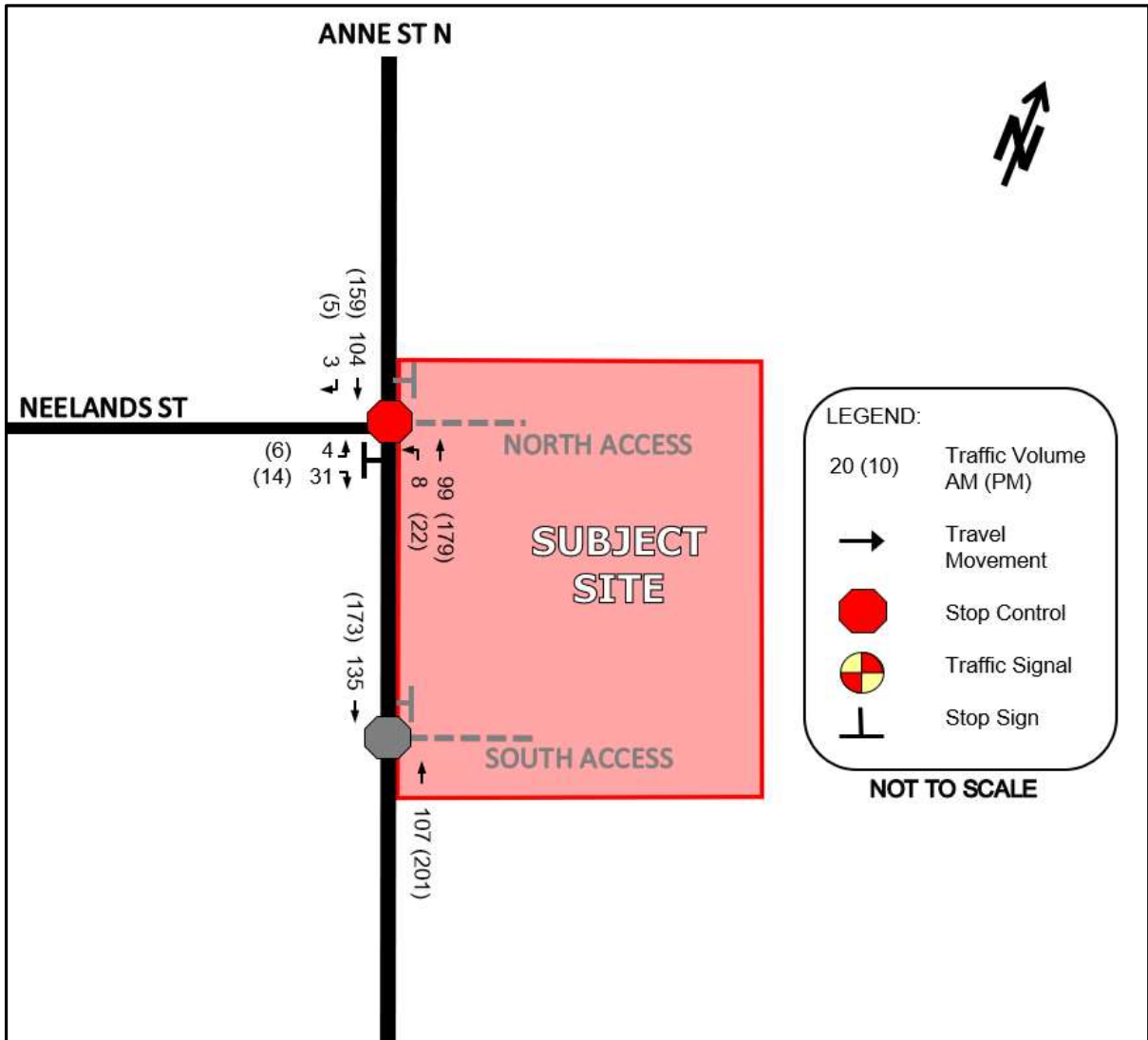

Figure 5 – Background (2027) Traffic Volumes



3 Intersection Operation without Proposed Development

3.1 Introduction

Existing and background horizon operational conditions were established to determine how the street network within the study area is currently functioning without the proposed development. This provides a base case scenario to compare with future development scenarios. Traffic operations within the study area were evaluated using the existing and future background traffic volumes with the existing road configuration and traffic control. The intersection performance was measured using the traffic analysis software, Synchro 11, a deterministic model that employs Highway Capacity Manual and Intersection Capacity Utilization methodologies for analyzing intersection operations. These procedures are accepted by provincial and municipal agencies throughout North America.

Synchro 11 enables the study area to be graphically defined in terms of streets and intersections, along with their geometric and traffic control characteristics. The user is able to evaluate both signalized and unsignalized intersections in relation to each other, thus not only providing level of service for the individual intersections, but also enabling an assessment of the impact the various intersections in a network have on each other in terms of spacing, traffic congestion, delay, and queuing.

The intersection operations were also evaluated in terms of the LOS. LOS is a common measure of the quality of performance at an intersection and is defined in terms of vehicular delay. This delay includes deceleration delay, queue move-up time, stopped delay, and acceleration delay. LOS is expressed on a scale of A through F, where LOS A represents very little delay (i.e. less than 10 seconds per vehicle) and LOS F represents very high delay (i.e. greater than 50 seconds per vehicle for a stop sign controlled intersection and greater than 80 seconds per vehicle for a signalized intersection).

The LOS criteria for signalized and stop sign-controlled intersections are shown in **Table 2**. A description of traffic performance characteristics is included for each LOS.

Table 2 – Level of Service Criteria for Intersections

LOS	LOS Description	Control Delay (seconds per vehicle)	
		Signalized Intersections	Stop Controlled Intersections
A	Very low delay; most vehicles do not stop (Excellent)	less than 10.0	less than 10.0
B	Higher delay; more vehicles stop (Very Good)	between 10.0 and 20.0	between 10.0 and 15.0
C	Higher level of congestion; number of vehicles stopping is significant, although many still pass through intersection without stopping (Good)	between 20.0 and 35.0	between 15.0 and 25.0
D	Congestion becomes noticeable; vehicles must sometimes wait through more than one red light; many vehicles stop (Satisfactory)	between 35.0 and 55.0	between 25.0 and 35.0
E	Vehicles must often wait through more than one red light; considered by many agencies to be the limit of acceptable delay	between 55.0 and 80.0	between 35.0 and 50.0
F	This level is considered to be unacceptable to most drivers; occurs when arrival flow rates exceed the capacity of the intersection (Unacceptable)	greater than 80.0	greater than 50.0

3.2 Existing Intersection Operation

The results of the LOS analysis under existing (2024) traffic volumes during the AM and PM peak hour can be found below in **Table 3**. Existing intersection geometry and traffic control have been utilized for this scenario. Detailed output of the Synchro analysis can be found in **Appendix C**.

Table 3 – Existing (2024) LOS

Location (N-S Street / E-W Street)	Weekday AM Peak Hour					Weekday PM Peak Hour				
	V/C	Delay (s)	LOS	95% Queue (m)		V/C	Delay (s)	LOS	95% Queue (m)	
				Storage	Model				Storage	Model
Anne Street North / Neelands Street (unsignalized)	-	1.9	A	-	-	-	1.3	A	-	-
EB	0.05	9.2	A	-	1	0.04	9.9	A	-	1

The results of the LOS analysis indicate that the study area intersection is operating within the typical design limits noted in Section 3.1.

An analysis was completed for left turn movements at the study area intersection, based on the criteria outlined in Appendix 9A of the Ontario Ministry of Transportation Design Supplement for TAC Geometric Design Guide for Canadian Roads June 2017 [MTO DS]. According to the above-noted criteria a left turn lane is not warranted (results are provided in **Appendix G**).

A review of the need for an auxiliary right turn lane at the study area intersection was completed as part of our analysis. The results of the Synchro analysis indicate that there is excess capacity for all movements; consequently, an auxiliary right turn lane is not recommended.

Further consideration for traffic signal improvements were considered at the study area unsignalized intersection based on the Ontario Traffic Manual Book 12 *Signal Justification*. The results indicate that traffic signals are not warranted at the intersection (results are provided in **Appendix H**).

No additional improvements are recommended within the study area.

3.3 Background (2027) Intersection Operation

The results of the LOS analysis under background (2027) traffic volumes during the AM and PM peak hour can be found below in **Table 4**. Existing intersection geometry has been utilized for this scenario and traffic control has been utilized for this scenario. Detailed output of the Synchro analysis can be found in **Appendix D**.

Table 4 – Background (2027) LOS

Location (N-S Street / E-W Street)	Weekday AM Peak Hour					Weekday PM Peak Hour				
	V/C	Delay (s)	LOS	95% Queue (m)		V/C	Delay (s)	LOS	95% Queue (m)	
				Storage	Model				Storage	Model
Anne Street North / Neelands Street (unsignalized)	-	1.9	A	-	-	-	1.4	A	-	-
EB	0.06	9.3	A	-	1	0.05	9.9	A	-	1

The results of the LOS analysis indicate that the study area intersection is operating within the typical design limits noted in Section 3.1.

An analysis was completed for left turn movements at the study area unsignalized intersection, based on the criteria outlined in Appendix 9A of the MTO DS. According to the above-noted criteria a left turn lane is not warranted (results are provided in **Appendix G**).

A review of the need for an auxiliary right turn lane at the study area intersection was completed as part of our analysis. The results of the Synchro analysis indicate that there is excess capacity for all movements; consequently, an auxiliary right turn lane is not recommended.

Further consideration for traffic signal improvements were considered at the study area intersection based on the Ontario Traffic Manual Book 12 *Signal Justification*. The results indicate that traffic signals are not warranted at the intersection (results are provided in **Appendix H**).

No additional improvements are recommended within the study area.

4 Proposed Development Traffic Generation and Assignment

4.1 Traffic Generation

The traffic generation for proposed development has been estimated based the type of land use, development size and data provided in the ITE Trip Generation Manual. The following ITE land use has been applied to estimate the traffic for the proposed development:

- ITE land use 210 – (Single-Family Detached Housing).
- ITE land use 215 – (Single-Family Attached Housing).

The utilized traffic rates and estimated trip generation of the proposed development is illustrated below in **Table 5** and **Table 6**.

Table 5 – ITE Traffic Generation Trip Rates (Subject Site)

Land Use	Trip Basis	AM Peak Hour			PM Peak Hour		
		IN	OUT	TOTAL	IN	OUT	TOTAL
Single-Family Detached Housing ITE Land Use: 210	equation (units)	Ln(T) = 0.91*Ln(X) +0.12			Ln(T) = 0.94*Ln(X) +0.27		
	distribution	25%	75%	100%	63%	37%	100%
Single-Family Attached Housing ITE Land Use: 215	rate (units)	0.12	0.36	0.48	0.34	0.23	0.57

Table 6 – Estimated Trip Generation of the Proposed Development

Land Use		Size	AM Peak Hour			PM Peak Hour		
			IN	OUT	TOTAL	IN	OUT	TOTAL
Subject Site	Stacked Townhouses (Anne St)	84 units	10	30	40	28	20	48
	Semi-Detached (Harrison Cres)	8 units	1	3	4	3	2	5
	Single Detached (Harrison Cres)	4 units	1	3	4	3	2	5
Total			12	36	48	34	24	58

In order to be conservative, no transportation modal split reduction has been applied to the above-noted traffic generation calculation.

4.2 Traffic Assignment

For the purposes of this study, it has been assumed that all traffic generated by the proposed development will be new traffic and would not be in the study area if the development was not constructed.

In Section 4.1, the anticipated percentage of new traffic entering and exiting during the peak hour was established. The distribution of the proposed development traffic has been calculated based on the 2016 Transportation Tomorrow Survey [TTS] data for traffic zone 8516 retrieved using the TTS Internet Data Retrieval System [IDRS] (output attached as **Appendix F**). TTS data provides historical origin and destination work trip percentages for specific areas within the County and the Greater Toronto and Hamilton Area [GTHA].

Traffic distribution for the trips generated by the subject site during the AM and PM peak hour is expected to generally follow commuter travel patterns. Our analysis is based on egress traffic during the AM peak hour. Logically, the distribution of ingress traffic will follow the inverse of the exiting traffic distribution. For each of the individual areas identified in the TTS data, we have selected the probable route of travel, assuming that people will select their route primarily based on travel time.

The distribution of traffic for the proposed development is illustrated in **Table 7**, using the methodology outlined above.

Table 7 – Proposed Development Traffic Distribution

Travel Direction (to / from)	Percent of Total Traffic Generation
North via Anne Street North	11%
South via Anne Street North	86%
West via Neeland Street	3%
TOTAL	100%

The traffic generated by the proposed development has been further assigned to the North and South Accesses based on the number of parking spaces available via each access. It is noted that the majority of the traffic volumes generated by the 12 units on Harrison Crescent will not traverse the study intersections, as they will travel via Hanmer Street to the east, and Anne Street to the south of the study area. The total traffic generated by the 12 units would be six trips out and two trips in during the AM

peak hour and four trips out and six trips in during the PM peak hour. This volume of traffic will have a negligible impact on the traffic operations at the local intersection.

The site traffic assignment for the site trips during the AM and PM peak hour is illustrated in **Figure 6**.

Figure 6 – Site Traffic Assignment

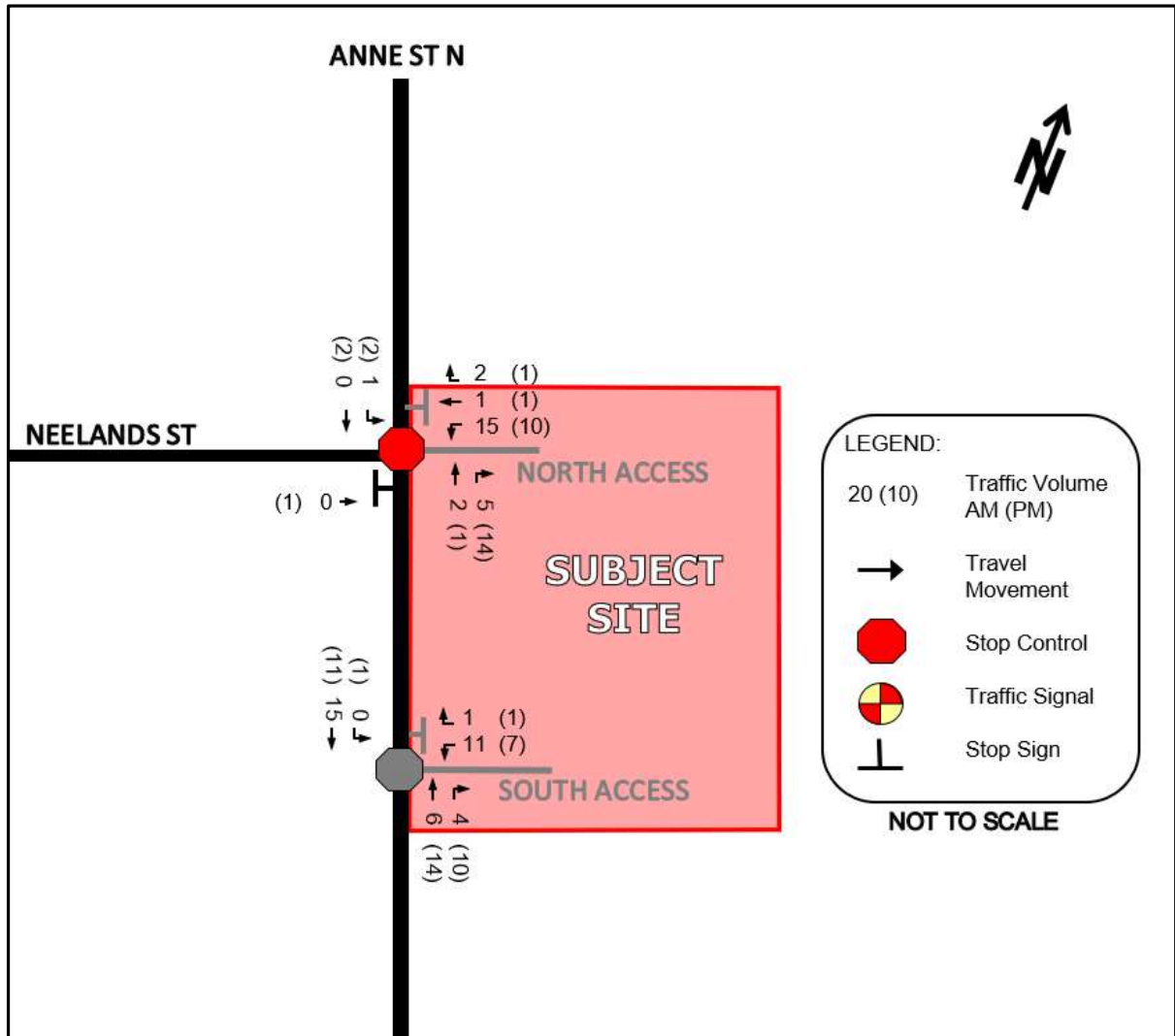

4.3 Total Horizon Year Traffic Volumes with the Proposed Development

For the total (2027) horizon year traffic volumes, the proposed development traffic was added to the background (2027) traffic volumes. The resulting total (2027) horizon year traffic volumes for the AM and PM peak hour are illustrated in **Figure 7**.

Figure 7 – Total (2027) Traffic Volumes

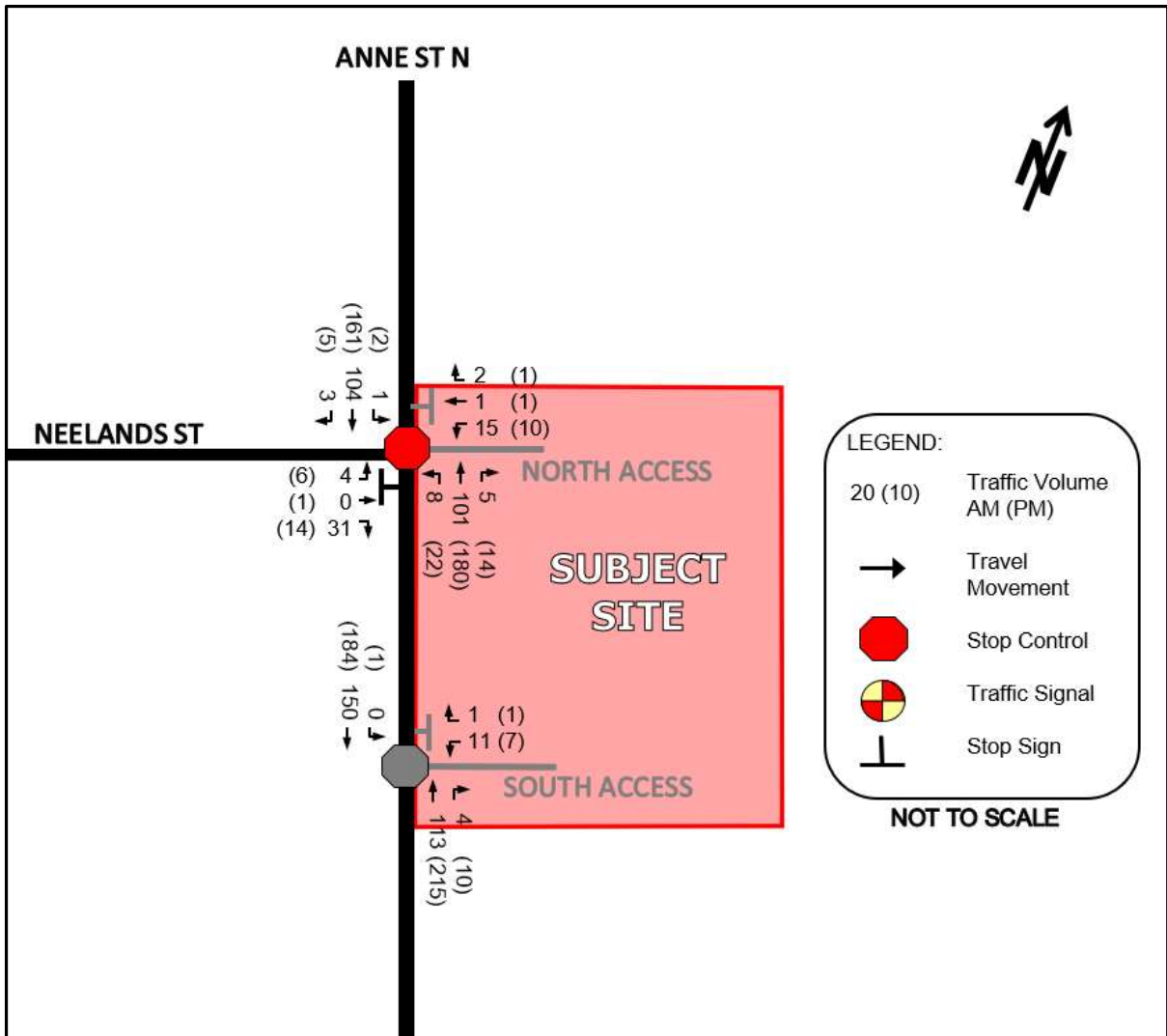

5 Intersection Operation with Proposed Development

5.1 Total (2027) Intersection Operation

The results of the LOS analysis under total (2027) traffic volumes during the AM and PM peak hour can be found below in **Table 8**. Existing intersection geometry and traffic control have been utilized for this scenario. Detailed output of the Synchro analysis can be found in **Appendix E**.

Table 8 – Total (2027) LOS

Location (N-S Street / E-W Street)	Weekday AM Peak Hour					Weekday PM Peak Hour				
	V/C	Delay (s)	LOS	95% Queue (m)		V/C	Delay (s)	LOS	95% Queue (m)	
				Storage	Model				Storage	Model
Anne Street North / Neelands Street (unsignalized)	-	2.4	A	-	-	-	1.7	A	-	-
EB	0.06	9.3	A	-	2	0.05	10.3	B	-	1
WB	0.03	10.8	B	-	1	0.02	12.0	B	-	1
Anne Street North / South Access (unsignalized)	-	0.4	A	-	-	-	0.2	A	-	-
WB	0.02	10.1	B	-	1	0.02	11.2	B	-	1

The results of the LOS analysis indicate that all the study area intersections are operating within the typical design limits noted in Section 3.1.

An analysis was completed for left turn movements at the study area unsignalized intersections, based on the criteria outlined in Appendix 9A of the MTO DS. According to the above-noted criteria a left turn lane is not warranted (results are provided in **Appendix G**).

A review of the need for an auxiliary right turn lane at the study area intersections was completed as part of our analysis. The results of the Synchro analysis indicate that there is excess capacity for all movements; consequently, an auxiliary right turn lane is not recommended.

Further consideration for traffic signal improvements were considered at the study area intersections based on the Ontario Traffic Manual Book 12 *Signal Justification*. The results indicate that traffic signals are not warranted at the intersection (results are provided in **Appendix H**).

No additional improvements are recommended within the study area.

5.2 Site Access & Intersection Spacing

The North Access will operate efficiently as a full movement driveway, with one-way stop control for the westbound movements. A single ingress and egress lane will provide the necessary capacity to service the proposed development.

The South Access will continue to operate efficiently as a full movement driveway with one-way stop control for westbound movements. A single ingress and egress lane will provide the necessary capacity to service the proposed development.

The proposed spacing between the North Access and Enbridge Barrie Gas Station Driveway to the north (approximately 22 metres) is greater than the minimum driveway spacing requirements as per the TAC Guidelines – Figure 8.8.2 (Suggested Minimum Corner Clearances to Accesses or Public Lanes at Major Intersections) – 5 metres for industrial driveways.

The proposed spacing between the South Access and the existing residential driveway to the south (approximately 17 metres) is less than the minimum driveway spacing requirements as per the TAC Guidelines – Figure 8.8.2 (Suggested Minimum Corner Clearances to Accesses or Public Lanes at Major Intersections) – 35 meters for arterial roads for unsignalized conditions. However, considering the nature of the adjacent driveway (very low-traffic volume), the spacing is not a concern.

The proposed spacing between the North Access and the South Access (approximately 104 meters) exceeds the minimum driveway spacing requirements as per the TAC Guidelines – Figure 8.8.2 (Suggested Minimum Corner Clearances to Accesses or Public Lanes at Major Intersections) – 35 meters for arterial roads for unsignalized conditions.

Consequently, there are no issues with the location of the proposed Site Access driveways.

The Subject Site will provide sidewalk along the frontage of Anne Street, providing pedestrian connectivity to the existing sidewalk to the south.

5.3 Sight Distance Review

A review of the available sight distance for the proposed Site Access was completed as part of this analysis.

The sight distance north and south of the North and South Access driveways on Anne Street North (greater than 300 metres in both directions), exceeds both the minimum stopping and intersection sight distance requirements as per the TAC Guidelines for a design speed of 60 km/h (85 and 130 metres, respectively).

There are no issues with the sight distance available for the proposed North and South Accesses.

5.4 Construction Staging

A review of the construction staging plan was completed as it relates to parking of trades people, delivery of construction material, maintenance of adjacent property access, pedestrian movements, City infrastructure, etc.

Access to the Subject Site will be provided via the existing north and south driveways onto Anne Street North. The driveways will be the primary accesses throughout the entire construction period (i.e., demolition, site preparation, servicing and erection etc.).

Deliveries and trades parking can be accommodated on-site. The expected construction staging plan is not expected to impede or prevent access to the neighboring lots.

Construction activities within the site (including start-up and warm-up of equipment) will only occur between 07:00 and 19:00 on weekdays and Saturdays, per City of Barrie by-law. No construction activities will occur outside the above-noted periods without approval from the City.

Signage shall be posted at all site access as required, notifying visitors that check-in at the site office is mandatory. Signage will also be provided to identify the area as a 'construction site', requiring all visitors be equipped with personal protection equipment suitable for a construction zone (hard hat,

footwear, high visibility gear). Signage will also be provided informing that access to the site is limited to authorized personnel only.

5.5 Swept Path Analysis

A swept path analysis has been provided in **Appendix I** to illustrate that the following vehicles can access the site as intended:

- Passenger Vehicle (TAC P);
- Molok Truck; and
- Fire Truck.

6 Parking Review

The City's Zoning By-law 2009-141 [ZBL] and the City's Comprehensive Zoning By-law [Draft ZBL] - Draft 2 (June 2023) provide parking requirements for a variety of building types and land uses. **Table 9** summarizes the parking requirement for the proposed development uses, according to the City's ZBL and Draft ZBL.

Table 9 – Zoning By-law Parking Requirements

Category	Zoning By-Law Section	Parking Standard	Size	Required	Provided	Net Supply
City's Zoning By-Law (2009-141)						
Stacked Townhouses	4.6.1	1.5 spaces / unit (including visitor parking) Tandem not permitted	84 units	126 spaces	132 spaces	+6
Residential Building < 3 dwelling units		1.5 spaces / unit (including visitor parking) Tandem permitted	12 units	18 spaces	24 spaces	+6
<i>Accessible Parking</i>	4.6.4	<i>2 Type A + 2 Type B</i>		<i>4 spaces</i>	<i>2 Type A 2 Type B</i>	-

The above-noted parking supply exceeds the parking requirements for the proposed development. Overflow parking onto adjacent on-street parking or private parking lots is not expected.

7 Summary

Wynstar Anne Street LP Inc. retained **JD Engineering** to prepare this traffic brief in support of the proposed development located on the east side of Anne Street North, west of Harrison Crescent, in the City of Barrie [City]. The proposed Site Plan is shown in **Appendix A**. This chapter summarizes the conclusions and recommendations from the study.

1. The proposed development is expected to generate a total of 47 AM and 56 PM peak hour primary trips.
2. Detailed turning movement traffic and pedestrian counts were commissioned by JD Engineering.
3. An intersection operation analysis was completed at the study area intersections, using the existing and background (2027) traffic volumes, with consideration for the projected adjacent

development traffic growth and without the proposed development traffic. No improvements are recommended within the study area.

4. An estimate of the amount of traffic that would be generated by the Subject Site was prepared and assigned to the study area streets and intersections.
5. An intersection operation analysis was completed under total (2027) traffic volumes with the proposed development operational at the study area intersections. No improvements are recommended within the study area.
6. The North Access will operate efficiently as a full movement access, with one-way stop control for egress movements. A single lane for ingress and egress movements will provide the necessary capacity to convey the traffic volume generated by the proposed development.
7. The South Access will operate efficiently as a full movement access, with one-way stop control for egress movements. A single lane for ingress and egress movements will provide the necessary capacity to convey the traffic volume generated by the proposed development.
8. The proposed parking supply exceeds the minimum parking requirement specified in the City's Zoning By-Law.
9. In summary, the proposed development will not cause any operational issues and will not add significant delay or congestion to the local roadway network.

Appendix A – Site Plan

RESIDENTIAL MULTIPLE DWELLING SECOND DENSITY (RM2) ZONE: BLOCK / CLUSTER / STREET / STACKED TOWNHOUSE 84 UNITS		
Provisions	Required	Provided
Lot Area (min.)	720.00m ²	7,927.30m ² (Development Limit excl. semi-detached lots & road widening)
Lot Frontage (min.)	21.00m	129.54m (Anne St. N.)
Front Yard to Dwelling Unit (min.)	7.00m	3.00m
Side Yards (min.)	1.80m	- Bldg. 'E': 3.00m
Interior Side Yard to Attached Garage (min.)	0.60m	N.A.
Rear Yard (min.)	7.00m	3.50m (Bldg 'E')
Landscaped Open Space (min.)	35%	43.51% (3,449.24m ² - excl. bldg. areas and private laneway)
Lot Coverage (max.)	35%	40.73% (3,229.54m ²)
Height of Main Bldg. (max.)	10.00m	14.70m
Outdoor Amenity Area (5.2.5.2.)	1,008.00m ² for 84 units (12.00m ² / unit in a consolidated form)	1,478.50 for 84 units (17.60m ² / unit in a consolidated form)
Max. G.F.A.	60%	117.09% (9,282.32m ²)
Required Parking: Residential Bldg. containing more than 3 dwelling units	126 spaces for 84 units (1.5 spaces / DU. Tandem parking not permitted)	132 spaces for 84 units - 30 surface parking spaces - 102 covered parking spaces
Required Barrier Free Parking	2 Type 'A' and 2 Type 'B' B.F. spaces	2 Type 'A' and 2 Type 'B' B.F. spaces
Density (5.2.5.1.a)	40 units / ha	106.33 units / ha (84 units / 0.79ha)

RESIDENTIAL SEMI-DETACHED DWELLING FIRST DENSITY (RM1) ZONE 8 UNITS:		
Provisions	Required	Provided
Lot Area (min.) (5.3.4.1)(4)(6)	300.00m ² / DU	191.81m ² / DU (Lot 01)
Lot Frontage (min.) (5.3.4.1)	9.00m / DU	8.0 m (Lots 1, 2, 3 & 4)
Front Yard to Dwelling Unit (min.) (5.2.3.1.a)	4.50m	5.09m
Front Yard to Attached Garage (min.)	7.00m	6.56m (Lot 1)
Side Yards (min.) (5.2.3.1.a)	1.20m	1.25 m
Interior Side Yard to Attached Garage (min.)	0.60m	1.25 m
Rear Yard (min.)	7.00m	6.00m (Lots 1, 2, 3 & 4)
Lot Coverage (max.) (5.2.3.1.a)	45%	42.86% (82.21m ² /DU - Lot 01)
Height of Main Bldg. (max.)	10.00m	< 10.0m
Required Parking: Residential Bldg. containing not more than 3 dwelling units	1.5 spaces / DU. Tandem parking will be permitted.	2 spaces / DU. Tandem parking will be permitted.

RESIDENTIAL SINGLE DETACHED DWELLING THIRD DENSITY (R3) ZONE 4 UNITS		
Provisions	Required	Provided
Lot Area (min.)	400.00m ²	317.67m ² (Lot 6)
Lot Frontage (min.)	12.00m	12.00 m (Harrison Cres.)
Front Yard to Dwelling Unit (min.)	4.50m	5.51m
Front Yard to Attached Garage (min.)	7.00m	Lot 7 - 6.48m
Side Yards (min.)	1.20m	1.21m
Interior Side Yard to Attached Garage (min.)	0.60m	1.21m
Rear Yard (min.)	7.00m	Lot 5 - 6.04m
Lot Coverage (max.) (5.2.3.1.a)	45%	35.67% (Lot 6 - 113.30m ²)
Height of Main Bldg. (max.)	10.00m	< 10.00m
Required Parking: Residential Bldg. containing not more than 3 dwelling units	1.5 spaces / DU. Tandem parking will be permitted.	2 spaces / DU. Tandem parking will be permitted.

Storm Pipes
Sanitary Pipes
Water Mains

Residential
Anne St. N.

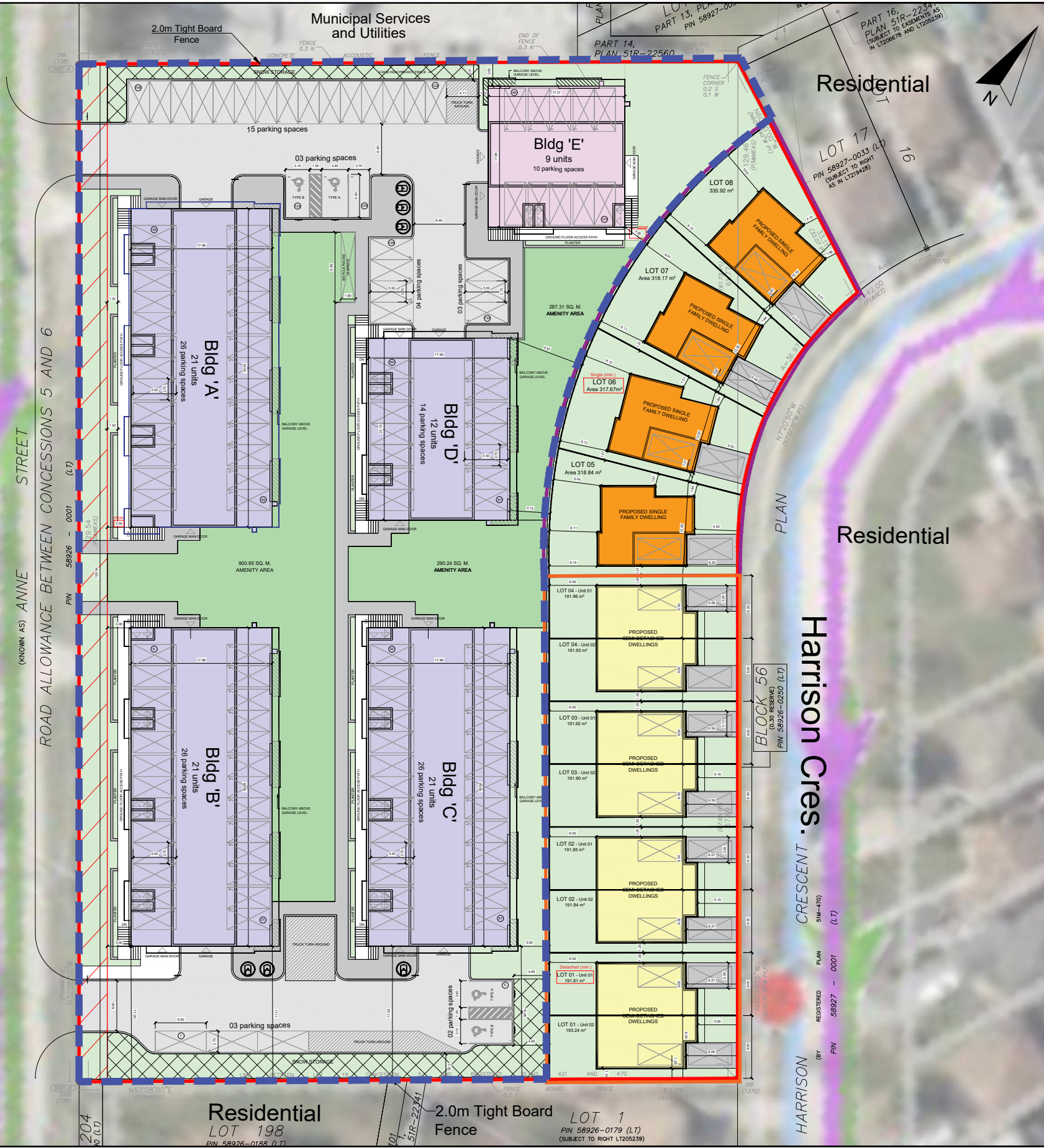

CONCEPTUAL SITE PLAN

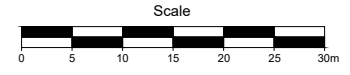

- LEGEND**
- Subject Site (11,220.50m² / 1.12ha)
 - Potential 3.50m Road Widening (T.B.D.)
 - 3 Storey Stacked Back-to-Back Townhouse Units (A - D)
 - Bldg. Area ('A' to 'D'): 728.90 m² / bldg.
 - Bldg. Area ('E'): 424.32 m²
 - Total units: 75
 - 3 Storey Stacked Back-to-Back Townhouse Units (E)
 - Bldg. Area: 312.31 m²
 - Total units: 9
 - 2 Storey Semi-Detached Lots:
 - Total units: 8
 - 2 Storey Single Detached Lots:
 - Total units: 4
 - Raised Walkway
 - Amenity Area (1,478.50m²)
 - Snow Storage Area (344.39m²)

Source: City of Barrie, Comprehensive Zoning By-Law 2009 - 141, Office Consolidation Jan. 2024

Note: This drawing is for discussion purposes only. The information shown is approximate and subject to change.

CONCEPTUAL SITE PLAN - 96 UNITS

435 ANNE ST. N., BARRIE

SCHEDULE OF REVISIONS

NO.	DESCRIPTION	DATE

IPS INNOVATIVE PLANNING SOLUTIONS CELEBRATING 20 YEARS
 PLANNERS • PROJECT MANAGERS • LAND DEVELOPERS
 647 WELHAM ROAD, UNIT 9, BARRIE, ON, L4N 0B7
 Tel: 705-812-3281 Fax: 705-812-3438 E: info@ipsconsultinginc.com www.ipsconsultinginc.com

Date: January 07, 2025	Drawn By: A.G.
File: 23 - 1327	Checked: G.B.

Appendix B – Traffic Count Data



Project #24-146 - JD Engineering Inc

Intersection Count Report

Intersection: Anne St N & Neelands St
Municipality: Barrie
Count Date: Tuesday, Apr 16, 2024
Site Code: 2414600001
Count Categories: Cars, Trucks, Bicycles, Pedestrians
Count Period: 07:00-09:00, 16:00-19:00
Weather: Clear
Comments:

Traffic Count Map

Intersection: Anne St N & Neelands St
Site Code: 241460001
Municipality: Barrie
Count Date: Apr 16, 2024

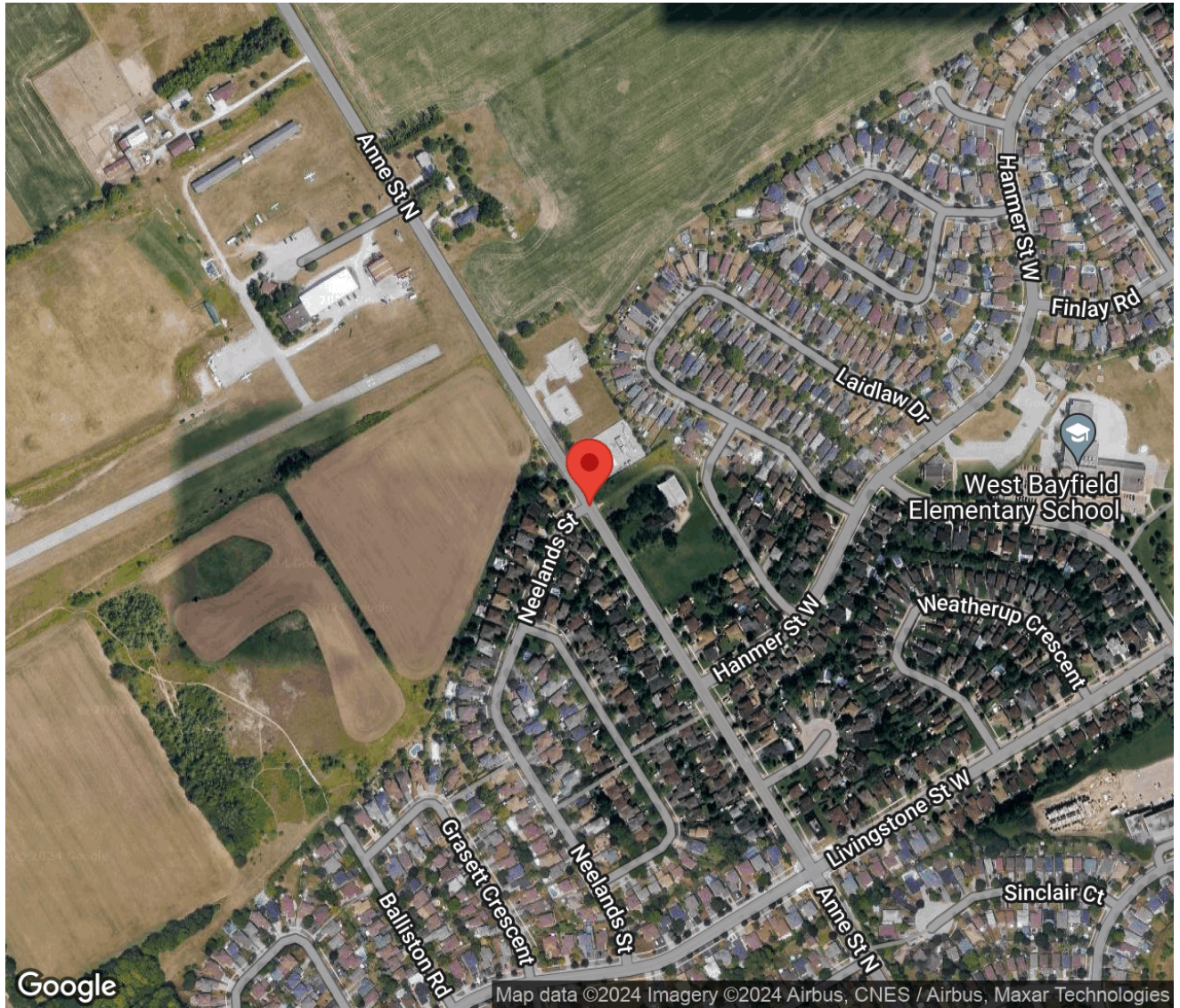



Traffic Count Summary

Intersection: Anne St N & Neelands St
 Site Code: 241460001
 Municipality: Barrie
 Count Date: Apr 16, 2024

Anne St N - Traffic Summary

Hour	North Approach Totals						South Approach Totals						Total
	Includes Cars, Trucks, Bicycles						Includes Cars, Trucks, Bicycles						
	Left	Thru	Right	U-Turn	Total	Peds	Left	Thru	Right	U-Turn	Total	Peds	
07:00 - 08:00	0	73	2	0	75	0	8	82	0	0	90	0	165
08:00 - 09:00	0	98	3	0	101	0	8	93	0	0	101	0	202
BREAK													
16:00 - 17:00	0	144	6	0	150	0	21	168	0	0	189	0	339
17:00 - 18:00	0	116	9	0	125	0	17	149	0	0	166	0	291
18:00 - 19:00	0	91	1	0	92	0	13	75	0	1	89	0	181
GRAND TOTAL	0	522	21	0	543	0	67	567	0	1	635	0	1178



Traffic Count Summary

Intersection: Anne St N & Neelands St
 Site Code: 241460001
 Municipality: Barrie
 Count Date: Apr 16, 2024

Private Driveway - Traffic Summary

Hour	East Approach Totals						West Approach Totals						Total
	Includes Cars, Trucks, Bicycles						Includes Cars, Trucks, Bicycles						
	Left	Thru	Right	U-Turn	Total	Peds	Left	Thru	Right	U-Turn	Total	Peds	
07:00 - 08:00	0	0	0	0	0	1	2	0	13	0	15	3	15
08:00 - 09:00	0	0	0	0	0	0	4	0	29	0	33	1	33
BREAK													
16:00 - 17:00	0	0	0	0	0	0	5	0	13	0	18	4	18
17:00 - 18:00	0	0	0	0	0	0	6	0	17	0	23	2	23
18:00 - 19:00	0	0	0	0	0	1	4	0	16	0	20	8	20
GRAND TOTAL	0	0	0	0	0	2	21	0	88	0	109	18	109



Traffic Count Data

Intersection: Anne St N & Neelands St
 Site Code: 2414600001
 Municipality: Barrie
 Count Date: Apr 16, 2024

North Approach - Anne St N

Start Time	Cars					Trucks					Bicycles					Total Peds	
	←	↑	→	↻	Total	←	↑	→	↻	Total	←	↑	→	↻	Total		
07:00	0	7	0	0	7	0	0	0	0	0	0	0	0	0	0	0	0
07:15	0	15	0	0	15	0	0	0	0	0	0	0	0	0	0	0	0
07:30	0	25	1	0	26	0	2	0	0	2	0	0	0	0	0	0	0
07:45	0	22	1	0	23	0	2	0	0	2	0	0	0	0	0	0	0
08:00	0	25	2	0	27	0	1	0	0	1	0	0	0	0	0	0	0
08:15	0	22	0	0	22	0	1	0	0	1	0	0	0	0	0	0	0
08:30	0	22	1	0	23	0	1	0	0	1	0	0	0	0	0	0	0
08:45	0	26	0	0	26	0	0	0	0	0	0	0	0	0	0	0	0
SUBTOTAL	0	164	5	0	169	0	7	0	0	7	0	0	0	0	0	0	0



Traffic Count Data

Intersection: Anne St N & Neelands St
 Site Code: 2414600001
 Municipality: Barrie
 Count Date: Apr 16, 2024

North Approach - Anne St N

Start Time	Cars					Trucks					Bicycles					Total Peds
	←	↑	→	↻	Total	←	↑	→	↻	Total	←	↑	→	↻	Total	
16:00	0	32	1	0	33	0	1	0	0	1	0	1	0	0	1	0
16:15	0	36	2	0	38	0	1	0	0	1	0	0	0	0	0	0
16:30	0	36	2	0	38	0	1	0	0	1	0	0	0	0	0	0
16:45	0	35	1	0	36	0	1	0	0	1	0	0	0	0	0	0
17:00	0	40	0	0	40	0	0	0	0	0	0	0	0	0	0	0
17:15	0	33	3	0	36	0	0	0	0	0	0	0	1	0	1	0
17:30	0	19	1	0	20	0	0	0	0	0	0	1	1	0	2	0
17:45	0	23	1	0	24	0	0	0	0	0	0	0	2	0	2	0
18:00	0	25	0	0	25	0	0	0	0	0	0	0	0	0	0	0
18:15	0	27	0	0	27	0	0	0	0	0	0	0	0	0	0	0
18:30	0	21	1	0	22	0	0	0	0	0	0	0	0	0	0	0
18:45	0	18	0	0	18	0	0	0	0	0	0	0	0	0	0	0
SUBTOTAL	0	345	12	0	357	0	4	0	0	4	0	2	4	0	6	0
GRAND TOTAL	0	509	17	0	526	0	11	0	0	11	0	2	4	0	6	0



Traffic Count Data

Intersection: Anne St N & Neelands St
 Site Code: 2414600001
 Municipality: Barrie
 Count Date: Apr 16, 2024

South Approach - Anne St N

Start Time	Cars					Trucks					Bicycles					Total Peds
	←	↑	→	↻	Total	←	↑	→	↻	Total	←	↑	→	↻	Total	
07:00	1	14	0	0	15	0	2	0	0	2	1	0	0	0	1	0
07:15	1	17	0	0	18	0	0	0	0	0	1	0	0	0	1	0
07:30	1	27	0	0	28	0	0	0	0	0	0	0	0	0	0	0
07:45	2	19	0	0	21	1	2	0	0	3	0	1	0	0	1	0
08:00	0	23	0	0	23	0	0	0	0	0	0	0	0	0	0	0
08:15	1	25	0	0	26	0	1	0	0	1	0	0	0	0	0	0
08:30	1	20	0	0	21	0	0	0	0	0	0	0	0	0	0	0
08:45	5	24	0	0	29	1	0	0	0	1	0	0	0	0	0	0
SUBTOTAL	12	169	0	0	181	2	5	0	0	7	2	1	0	0	3	0



Traffic Count Data

Intersection: Anne St N & Neelands St
 Site Code: 2414600001
 Municipality: Barrie
 Count Date: Apr 16, 2024

South Approach - Anne St N

Start Time	Cars					Trucks					Bicycles					Total Peds
	←	↑	→	↻	Total	←	↑	→	↻	Total	←	↑	→	↻	Total	
16:00	6	41	0	0	47	0	0	0	0	0	0	0	0	0	0	0
16:15	4	43	0	0	47	0	1	0	0	1	0	0	0	0	0	0
16:30	4	44	0	0	48	0	0	0	0	0	0	1	0	0	1	0
16:45	7	35	0	0	42	0	3	0	0	3	0	0	0	0	0	0
17:00	6	42	0	0	48	0	0	0	0	0	0	0	0	0	0	0
17:15	3	35	0	0	38	0	0	0	0	0	0	0	0	0	0	0
17:30	4	40	0	0	44	0	0	0	0	0	0	0	0	0	0	0
17:45	4	32	0	0	36	0	0	0	0	0	0	0	0	0	0	0
18:00	2	21	0	0	23	0	0	0	0	0	0	0	0	0	0	0
18:15	3	21	0	1	25	0	0	0	0	0	0	0	0	0	0	0
18:30	6	20	0	0	26	0	0	0	0	0	0	0	0	0	0	0
18:45	2	12	0	0	14	0	1	0	0	1	0	0	0	0	0	0
SUBTOTAL	51	386	0	1	438	0	5	0	0	5	0	1	0	0	1	0
GRAND TOTAL	63	555	0	1	619	2	10	0	0	12	2	2	0	0	4	0



Traffic Count Data

Intersection: Anne St N & Neelands St
 Site Code: 2414600001
 Municipality: Barrie
 Count Date: Apr 16, 2024

East Approach - Private Driveway

Start Time	Cars					Trucks					Bicycles					Total Peds
	←	↑	→	↻	Total	←	↑	→	↻	Total	←	↑	→	↻	Total	
07:00	0	0	0	0	0	0	0	0	0	0	0	0	0	0	0	0
07:15	0	0	0	0	0	0	0	0	0	0	0	0	0	0	0	0
07:30	0	0	0	0	0	0	0	0	0	0	0	0	0	0	0	0
07:45	0	0	0	0	0	0	0	0	0	0	0	0	0	0	0	1
08:00	0	0	0	0	0	0	0	0	0	0	0	0	0	0	0	0
08:15	0	0	0	0	0	0	0	0	0	0	0	0	0	0	0	0
08:30	0	0	0	0	0	0	0	0	0	0	0	0	0	0	0	0
08:45	0	0	0	0	0	0	0	0	0	0	0	0	0	0	0	0
SUBTOTAL	0	0	0	0	0	0	0	0	0	0	0	0	0	0	0	1



Traffic Count Data

Intersection: Anne St N & Neelands St
 Site Code: 2414600001
 Municipality: Barrie
 Count Date: Apr 16, 2024

West Approach - Neelands St

Start Time	Cars					Trucks					Bicycles					Total Peds	
	←	↑	→	↻	Total	←	↑	→	↻	Total	←	↑	→	↻	Total		
07:00	0	0	2	0	2	0	0	0	0	0	0	0	0	0	0	0	0
07:15	1	0	4	0	5	0	0	0	0	0	0	0	0	0	0	0	2
07:30	0	0	5	0	5	0	0	1	0	1	0	0	0	0	0	0	1
07:45	1	0	1	0	2	0	0	0	0	0	0	0	0	0	0	0	0
08:00	3	0	10	0	13	0	0	0	0	0	0	0	0	0	0	0	0
08:15	0	0	3	0	3	0	0	2	0	2	0	0	0	0	0	0	0
08:30	1	0	7	0	8	0	0	0	0	0	0	0	0	0	0	0	1
08:45	0	0	7	0	7	0	0	0	0	0	0	0	0	0	0	0	0
SUBTOTAL	6	0	39	0	45	0	0	3	0	3	0	0	0	0	0	0	4



Traffic Count Data

Intersection: Anne St N & Neelands St
 Site Code: 2414600001
 Municipality: Barrie
 Count Date: Apr 16, 2024

West Approach - Neelands St

Start Time	Cars					Trucks					Bicycles					Total Peds
	←	↑	→	↻	Total	←	↑	→	↻	Total	←	↑	→	↻	Total	
16:00	2	0	5	0	7	0	0	0	0	0	0	0	0	0	0	0
16:15	1	0	1	0	2	0	0	0	0	0	0	0	0	0	0	0
16:30	1	0	3	0	4	0	0	0	0	0	0	0	0	0	0	1
16:45	1	0	4	0	5	0	0	0	0	0	0	0	0	0	0	3
17:00	3	0	5	0	8	0	0	0	0	0	0	0	0	0	0	1
17:15	0	0	2	0	2	0	0	0	0	0	1	0	0	0	1	0
17:30	1	0	7	0	8	0	0	0	0	0	1	0	0	0	1	0
17:45	0	0	3	0	3	0	0	0	0	0	0	0	0	0	0	1
18:00	1	0	3	0	4	0	0	0	0	0	2	0	0	0	2	3
18:15	0	0	3	0	3	0	0	0	0	0	0	0	0	0	0	5
18:30	1	0	6	0	7	0	0	0	0	0	0	0	0	0	0	0
18:45	0	0	4	0	4	0	0	0	0	0	0	0	0	0	0	0
SUBTOTAL	11	0	46	0	57	0	0	0	0	0	4	0	0	0	4	14
GRAND TOTAL	17	0	85	0	102	0	0	3	0	3	4	0	0	0	4	18

Peak Hour Diagram

Specified Period

From: 07:00:00
To: 09:00:00

One Hour Peak

From: 08:00:00
To: 09:00:00

Intersection: Anne St N & Neelands St
Site Code: 2414600001
Count Date: Apr 16, 2024

Weather conditions: Clear

**** Unsignalized Intersection ****

Major Road: Anne St N runs N/S

North Approach

	Out	In	Total
	98	96	194
	3	1	4
	0	0	0
Totals	101	97	198

Anne St N

	0	0	0	0
	0	3	0	0
	3	95	0	0
Totals	3	98	0	0

East Approach

	Out	In	Total
	0	0	0
	0	0	0
	0	0	0
Totals	0	0	0

Neelands St

				Totals
	0	0	0	0
	0	0	4	4
	0	0	0	0
	0	2	27	29

Peds: 0

Peds: 1



Peds: 0

Peds: 0

Private Driveway

Totals			
0	0	0	0
0	0	0	0
0	0	0	0
0	0	0	0

West Approach

	Out	In	Total
	31	10	41
	2	1	3
	0	0	0
Totals	33	11	44

Totals			
8	93	0	0
7	92	0	0
1	1	0	0
0	0	0	0

Anne St N

South Approach

Out	In	Total
99	122	221
2	5	7
0	0	0
101	127	228

- Cars

- Trucks

- Bicycles

Comments



Peak Hour Summary

Intersection: Anne St N & Neelands St
 Site Code: 241460001
 Count Date: Apr 16, 2024
 Period: 07:00 - 09:00

Peak Hour Data (08:00 - 09:00)

Start Time	North Approach Anne St N						South Approach Anne St N						East Approach Private Driveway						West Approach Neelands St						Total Vehicles
	←	↑	→	↻	Peds	Total	←	↑	→	↻	Peds	Total	←	↑	→	↻	Peds	Total	←	↑	→	↻	Peds	Total	
08:00	0	26	2	0	0	28	0	23	0	0	0	23	0	0	0	0	0	0	3	0	10	0	0	13	64
08:15	0	23	0	0	0	23	1	26	0	0	0	27	0	0	0	0	0	0	0	0	5	0	0	5	55
08:30	0	23	1	0	0	24	1	20	0	0	0	21	0	0	0	0	0	0	1	0	7	0	1	8	53
08:45	0	26	0	0	0	26	6	24	0	0	0	30	0	0	0	0	0	0	0	0	7	0	0	7	63
Grand Total	0	98	3	0	0	101	8	93	0	0	0	101	0	0	0	0	0	0	4	0	29	0	1	33	235
Approach %	0	97	3	0	-	-	7.9	92.1	0	0	-	-	0	0	0	0	-	-	12.1	0	87.9	0	-	-	-
Totals %	0	41.7	1.3	0	-	43	3.4	39.6	0	0	-	43	0	0	0	0	-	-	1.7	0	12.3	0	-	14	-
PHF	0	0.94	0.38	0	0	0.9	0.33	0.89	0	0	0	0.84	0	0	0	0	0	0	0.33	0	0.73	0	0	0.63	0.92
Cars	0	95	3	0	-	98	7	92	0	0	-	99	0	0	0	0	-	-	4	0	27	0	-	31	228
% Cars	0	96.9	100	0	-	97	87.5	98.9	0	0	-	98	0	0	0	0	-	-	100	0	93.1	0	-	93.9	97
Trucks	0	3	0	0	-	3	1	1	0	0	-	2	0	0	0	0	-	-	0	0	2	0	-	2	7
% Trucks	0	3.1	0	0	-	3	12.5	1.1	0	0	-	2	0	0	0	0	-	-	0	0	6.9	0	-	6.1	3
Bicycles	0	0	0	0	-	0	0	0	0	0	-	0	0	0	0	0	-	-	0	0	0	0	-	0	0
% Bicycles	0	0	0	0	-	0	0	0	0	0	-	0	0	0	0	0	-	-	0	0	0	0	-	0	0
Peds	-	-	-	-	0	-	-	-	-	-	0	-	-	-	-	-	0	-	-	-	1	-	1	-	1
% Peds	-	-	-	-	0	-	-	-	-	-	0	-	-	-	-	-	0	-	-	-	100	-	-	-	-

Peak Hour Diagram

Specified Period

From: 16:00:00
To: 19:00:00

One Hour Peak

From: 16:15:00
To: 17:15:00

Intersection: Anne St N & Neelands St
Site Code: 2414600001
Count Date: Apr 16, 2024

Weather conditions: Clear

**** Unsignalized Intersection ****

Major Road: Anne St N runs N/S

North Approach

	Out	In	Total
	152	170	322
	3	4	7
	0	1	1
Totals	155	175	330

Anne St N

	0	0	0	0
	0	3	0	0
	5	147	0	0
Totals	5	150	0	0

East Approach

	Out	In	Total
	0	0	0
	0	0	0
	0	0	0
Totals	0	0	0

Neelands St

				Totals
	0	0	0	0
	0	0	6	6
	0	0	0	0
	0	0	13	13

Peds: 0

Peds: 5



Peds: 0

Peds: 0

Private Driveway

Totals			
0	0	0	0
0	0	0	0
0	0	0	0
0	0	0	0

West Approach

	Out	In	Total
	19	26	45
	0	0	0
	0	0	0
Totals	19	26	45

Totals				
21	169	0	0	
	21	164	0	0
	0	4	0	0
	0	1	0	0

Anne St N

South Approach

	Out	In	Total
	185	160	345
	4	3	7
	1	0	1
Totals	190	163	353

- Cars

- Trucks

- Bicycles

Comments



Peak Hour Summary

Intersection: Anne St N & Neelands St
 Site Code: 2414600001
 Count Date: Apr 16, 2024
 Period: 16:00 - 19:00

Peak Hour Data (16:15 - 17:15)

Start Time	North Approach Anne St N						South Approach Anne St N						East Approach Private Driveway						West Approach Neelands St						Total Vehic es
	←	↑	→	↻	Peds	Total	←	↑	→	↻	Peds	Total	←	↑	→	↻	Peds	Total	←	↑	→	↻	Peds	Total	
16:15	0	37	2	0	0	39	4	44	0	0	0	48	0	0	0	0	0	0	1	0	1	0	0	2	89
16:30	0	37	2	0	0	39	4	45	0	0	0	49	0	0	0	0	0	0	1	0	3	0	1	4	92
16:45	0	36	1	0	0	37	7	38	0	0	0	45	0	0	0	0	0	0	1	0	4	0	3	5	87
17:00	0	40	0	0	0	40	6	42	0	0	0	48	0	0	0	0	0	0	3	0	5	0	1	8	96
Grand Total	0	150	5	0	0	155	21	169	0	0	0	190	0	0	0	0	0	0	6	0	13	0	5	19	364
Approach %	0	96.8	3.2	0	-	-	11.1	88.9	0	0	-	-	0	0	0	0	-	-	31.6	0	68.4	0	-	-	
Totals %	0	41.2	1.4	0	-	42.6	5.8	46.4	0	0	-	52.2	0	0	0	0	-	-	1.6	0	3.6	0	-	5.2	
PHF	0	0.94	0.63	0	0	0.97	0.75	0.94	0	0	0	0.97	0	0	0	0	0	0	0.5	0	0.65	0	0	0.59	0.95
Cars	0	147	5	0	-	152	21	164	0	0	-	185	0	0	0	0	-	-	6	0	13	0	-	19	356
% Cars	0	98	100	0	-	98.1	100	97	0	0	-	97.4	0	0	0	0	-	-	100	0	100	0	-	100	97.8
Trucks	0	3	0	0	-	3	0	4	0	0	-	4	0	0	0	0	-	-	0	0	0	0	-	0	7
% Trucks	0	2	0	0	-	1.9	0	2.4	0	0	-	2.1	0	0	0	0	-	-	0	0	0	0	-	0	1.9
Bicycles	0	0	0	0	-	0	0	1	0	0	-	1	0	0	0	0	-	-	0	0	0	0	-	0	1
% Bicycles	0	0	0	0	-	0	0	0.6	0	0	-	0.5	0	0	0	0	-	-	0	0	0	0	-	0	0.3
Peds					0	-					0	-					0	-					5	-	5
% Peds					0	-					0	-					0	-					100	-	

Appendix C – Synchro Analysis Output – Existing Traffic Volumes

HCM Unsignalized Intersection Capacity Analysis
 3: Anne Street N & Neelands Street

435 Anne Street
 Existing (2024) - AM



Movement	EBL	EBR	NBL	NBT	SBT	SBR
Lane Configurations						
Traffic Volume (veh/h)	4	29	8	93	98	3
Future Volume (Veh/h)	4	29	8	93	98	3
Sign Control	Stop			Free	Free	
Grade	0%			0%	0%	
Peak Hour Factor	0.68	0.68	0.84	0.84	0.90	0.90
Hourly flow rate (vph)	6	43	10	111	109	3
Pedestrians	1					
Lane Width (m)	3.6					
Walking Speed (m/s)	1.2					
Percent Blockage	0					
Right turn flare (veh)						
Median type				None	None	
Median storage veh						
Upstream signal (m)						
pX, platoon unblocked						
vC, conflicting volume	242	112	113			
vC1, stage 1 conf vol						
vC2, stage 2 conf vol						
vCu, unblocked vol	242	112	113			
tC, single (s)	6.4	6.3	4.2			
tC, 2 stage (s)						
tF (s)	3.5	3.4	2.3			
p0 queue free %	99	95	99			
cM capacity (veh/h)	744	927	1409			
Direction, Lane #	EB 1	NB 1	SB 1			
Volume Total	49	121	112			
Volume Left	6	10	0			
Volume Right	43	0	3			
cSH	900	1409	1700			
Volume to Capacity	0.05	0.01	0.07			
Queue Length 95th (m)	1.4	0.2	0.0			
Control Delay (s)	9.2	0.7	0.0			
Lane LOS	A	A				
Approach Delay (s)	9.2	0.7	0.0			
Approach LOS	A					
Intersection Summary						
Average Delay			1.9			
Intersection Capacity Utilization			21.5%	ICU Level of Service	A	
Analysis Period (min)			15			

HCM Unsignalized Intersection Capacity Analysis
 3: Anne Street N & Neelands Street

25 Gouldie Street
 Existing (2024) - PM



Movement	EBL	EBR	NBL	NBT	SBT	SBR
Lane Configurations						
Traffic Volume (veh/h)	6	13	21	169	150	5
Future Volume (Veh/h)	6	13	21	169	150	5
Sign Control	Stop			Free	Free	
Grade	0%			0%	0%	
Peak Hour Factor	0.57	0.57	0.97	0.97	0.97	0.97
Hourly flow rate (vph)	11	23	22	174	155	5
Pedestrians	5					
Lane Width (m)	3.6					
Walking Speed (m/s)	1.2					
Percent Blockage	0					
Right turn flare (veh)						
Median type				None	None	
Median storage veh						
Upstream signal (m)						
pX, platoon unblocked						
vC, conflicting volume	380	162	165			
vC1, stage 1 conf vol						
vC2, stage 2 conf vol						
vCu, unblocked vol	380	162	165			
tC, single (s)	6.4	6.2	4.1			
tC, 2 stage (s)						
tF (s)	3.5	3.3	2.2			
p0 queue free %	98	97	98			
cM capacity (veh/h)	613	884	1420			
Direction, Lane #	EB 1	NB 1	SB 1			
Volume Total	34	196	160			
Volume Left	11	22	0			
Volume Right	23	0	5			
cSH	773	1420	1700			
Volume to Capacity	0.04	0.02	0.09			
Queue Length 95th (m)	1.1	0.4	0.0			
Control Delay (s)	9.9	1.0	0.0			
Lane LOS	A	A				
Approach Delay (s)	9.9	1.0	0.0			
Approach LOS	A					
Intersection Summary						
Average Delay			1.3			
Intersection Capacity Utilization			32.4%	ICU Level of Service	A	
Analysis Period (min)			15			

Appendix D – Synchro Analysis Output – Background Traffic Volumes

HCM Unsignalized Intersection Capacity Analysis
 3: Anne Street N & Neelands Street

435 Anne Street
 Background (2027) - AM



Movement	EBL	EBR	NBL	NBT	SBT	SBR
Lane Configurations						
Traffic Volume (veh/h)	4	31	8	99	104	3
Future Volume (Veh/h)	4	31	8	99	104	3
Sign Control	Stop			Free	Free	
Grade	0%			0%	0%	
Peak Hour Factor	0.68	0.68	0.84	0.84	0.90	0.90
Hourly flow rate (vph)	6	46	10	118	116	3
Pedestrians	1					
Lane Width (m)	3.6					
Walking Speed (m/s)	1.2					
Percent Blockage	0					
Right turn flare (veh)						
Median type				None	None	
Median storage (veh)						
Upstream signal (m)						
pX, platoon unblocked						
vC, conflicting volume	256	118	120			
vC1, stage 1 conf vol						
vC2, stage 2 conf vol						
vCu, unblocked vol	256	118	120			
tC, single (s)	6.4	6.3	4.2			
tC, 2 stage (s)						
tF (s)	3.5	3.4	2.3			
p0 queue free %	99	95	99			
cM capacity (veh/h)	731	919	1401			
Direction, Lane #	EB 1	NB 1	SB 1			
Volume Total	52	128	119			
Volume Left	6	10	0			
Volume Right	46	0	3			
cSH	893	1401	1700			
Volume to Capacity	0.06	0.01	0.07			
Queue Length 95th (m)	1.5	0.2	0.0			
Control Delay (s)	9.3	0.6	0.0			
Lane LOS	A	A				
Approach Delay (s)	9.3	0.6	0.0			
Approach LOS	A					
Intersection Summary						
Average Delay			1.9			
Intersection Capacity Utilization			21.8%	ICU Level of Service	A	
Analysis Period (min)			15			

HCM Unsignalized Intersection Capacity Analysis

3: Anne Street N & Neelands Street

25 Gouldie Street
Background (2027) - PM



















Movement	EBL	EBR	NBL	NBT	SBT	SBR
Lane Configurations						
Traffic Volume (veh/h)	6	14	22	179	159	5
Future Volume (Veh/h)	6	14	22	179	159	5
Sign Control	Stop			Free	Free	
Grade	0%			0%	0%	
Peak Hour Factor	0.57	0.57	0.97	0.97	0.97	0.97
Hourly flow rate (vph)	11	25	23	185	164	5
Pedestrians	5					
Lane Width (m)	3.6					
Walking Speed (m/s)	1.2					
Percent Blockage	0					
Right turn flare (veh)						
Median type				None	None	
Median storage (veh)						
Upstream signal (m)						
pX, platoon unblocked						
vC, conflicting volume	402	172	174			
vC1, stage 1 conf vol						
vC2, stage 2 conf vol						
vCu, unblocked vol	402	172	174			
tC, single (s)	6.4	6.2	4.1			
tC, 2 stage (s)						
tF (s)	3.5	3.3	2.2			
p0 queue free %	98	97	98			
cM capacity (veh/h)	595	874	1409			
Direction, Lane #	EB 1	NB 1	SB 1			
Volume Total	36	208	169			
Volume Left	11	23	0			
Volume Right	25	0	5			
cSH	764	1409	1700			
Volume to Capacity	0.05	0.02	0.10			
Queue Length 95th (m)	1.2	0.4	0.0			
Control Delay (s)	9.9	1.0	0.0			
Lane LOS	A	A				
Approach Delay (s)	9.9	1.0	0.0			
Approach LOS	A					
Intersection Summary						
Average Delay			1.4			
Intersection Capacity Utilization			33.4%	ICU Level of Service	A	
Analysis Period (min)			15			

Appendix E – Synchro Analysis Output – Total Traffic Volumes









HCM Unsignalized Intersection Capacity Analysis
 3: Anne Street N & Neelands Street/North Access

435 Anne Street
 Total (2027) - AM

												
Movement	EBL	EBT	EBR	WBL	WBT	WBR	NBL	NBT	NBR	SBL	SBT	SBR
Lane Configurations												
Traffic Volume (veh/h)	4	0	31	15	1	2	8	101	5	1	104	3
Future Volume (Veh/h)	4	0	31	15	1	2	8	101	5	1	104	3
Sign Control		Stop			Stop			Free			Free	
Grade		0%			0%			0%			0%	
Peak Hour Factor	0.68	0.68	0.68	0.92	0.92	0.92	0.84	0.84	0.84	0.90	0.90	0.90
Hourly flow rate (vph)	6	0	46	16	1	2	10	120	6	1	116	3
Pedestrians		1										
Lane Width (m)		3.6										
Walking Speed (m/s)		1.2										
Percent Blockage		0										
Right turn flare (veh)												
Median type							None				None	
Median storage veh												
Upstream signal (m)												
pX, platoon unblocked												
vC, conflicting volume	266	266	118	308	265	123	120			126		
vC1, stage 1 conf vol												
vC2, stage 2 conf vol												
vCu, unblocked vol	266	266	118	308	265	123	120			126		
tC, single (s)	7.1	6.5	6.3	7.1	6.5	6.2	4.2			4.1		
tC, 2 stage (s)												
tF (s)	3.5	4.0	3.4	3.5	4.0	3.3	2.3			2.2		
p0 queue free %	99	100	95	97	100	100	99			100		
cM capacity (veh/h)	683	637	919	611	638	933	1401			1473		
Direction, Lane #	EB 1	WB 1	NB 1	SB 1								
Volume Total	52	19	136	120								
Volume Left	6	16	10	1								
Volume Right	46	2	6	3								
cSH	884	636	1401	1473								
Volume to Capacity	0.06	0.03	0.01	0.00								
Queue Length 95th (m)	1.5	0.7	0.2	0.0								
Control Delay (s)	9.3	10.8	0.6	0.1								
Lane LOS	A	B	A	A								
Approach Delay (s)	9.3	10.8	0.6	0.1								
Approach LOS	A	B										
Intersection Summary												
Average Delay			2.4									
Intersection Capacity Utilization			22.3%		ICU Level of Service				A			
Analysis Period (min)			15									

















HCM Unsignalized Intersection Capacity Analysis
 8: Anne Street N & South Access

435 Anne Street
 Total (2027) - AM

						
Movement	WBL	WBR	NBT	NBR	SBL	SBT
Lane Configurations						
Traffic Volume (veh/h)	11	1	113	4	0	150
Future Volume (Veh/h)	11	1	113	4	0	150
Sign Control	Stop		Free		Free	
Grade	0%		0%		0%	
Peak Hour Factor	0.92	0.92	0.92	0.92	0.92	0.92
Hourly flow rate (vph)	12	1	123	4	0	163
Pedestrians						
Lane Width (m)						
Walking Speed (m/s)						
Percent Blockage						
Right turn flare (veh)						
Median type	None			None		
Median storage (veh)						
Upstream signal (m)						
pX, platoon unblocked						
vC, conflicting volume	288	125			127	
vC1, stage 1 conf vol						
vC2, stage 2 conf vol						
vCu, unblocked vol	288	125			127	
tC, single (s)	6.4	6.2			4.1	
tC, 2 stage (s)						
tF (s)	3.5	3.3			2.2	
p0 queue free %	98	100			100	
cM capacity (veh/h)	702	926			1459	
Direction, Lane #	WB 1	NB 1	SB 1			
Volume Total	13	127	163			
Volume Left	12	0	0			
Volume Right	1	4	0			
cSH	716	1700	1459			
Volume to Capacity	0.02	0.07	0.00			
Queue Length 95th (m)	0.4	0.0	0.0			
Control Delay (s)	10.1	0.0	0.0			
Lane LOS	B					
Approach Delay (s)	10.1	0.0	0.0			
Approach LOS	B					
Intersection Summary						
Average Delay			0.4			
Intersection Capacity Utilization			17.9%	ICU Level of Service		A
Analysis Period (min)			15			









HCM Unsignalized Intersection Capacity Analysis
 3: Anne Street N & Neelands Street/North Access

25 Gouldie Street
 Total (2027) - PM

												
Movement	EBL	EBT	EBR	WBL	WBT	WBR	NBL	NBT	NBR	SBL	SBT	SBR
Lane Configurations												
Traffic Volume (veh/h)	6	1	14	10	1	1	22	180	14	2	161	5
Future Volume (Veh/h)	6	1	14	10	1	1	22	180	14	2	161	5
Sign Control		Stop			Stop			Free			Free	
Grade		0%			0%			0%			0%	
Peak Hour Factor	0.57	0.57	0.57	0.92	0.92	0.92	0.97	0.97	0.97	0.97	0.97	0.97
Hourly flow rate (vph)	11	2	25	11	1	1	23	186	14	2	166	5
Pedestrians		5										
Lane Width (m)		3.6										
Walking Speed (m/s)		1.2										
Percent Blockage		0										
Right turn flare (veh)												
Median type								None			None	
Median storage veh												
Upstream signal (m)												
pX, platoon unblocked												
vC, conflicting volume	418	424	174	438	419	193	176			200		
vC1, stage 1 conf vol												
vC2, stage 2 conf vol												
vCu, unblocked vol	418	424	174	438	419	193	176			200		
tC, single (s)	7.1	6.5	6.2	7.1	6.5	6.2	4.1			4.1		
tC, 2 stage (s)												
tF (s)	3.5	4.0	3.3	3.5	4.0	3.3	2.2			2.2		
p0 queue free %	98	100	97	98	100	100	98			100		
cM capacity (veh/h)	536	514	872	507	517	854	1407			1384		
Direction, Lane #	EB 1	WB 1	NB 1	SB 1								
Volume Total	38	13	223	173								
Volume Left	11	11	23	2								
Volume Right	25	1	14	5								
cSH	716	525	1407	1384								
Volume to Capacity	0.05	0.02	0.02	0.00								
Queue Length 95th (m)	1.3	0.6	0.4	0.0								
Control Delay (s)	10.3	12.0	0.9	0.1								
Lane LOS	B	B	A	A								
Approach Delay (s)	10.3	12.0	0.9	0.1								
Approach LOS	B	B										
Intersection Summary												
Average Delay			1.7									
Intersection Capacity Utilization			34.3%		ICU Level of Service					A		
Analysis Period (min)			15									

HCM Unsignalized Intersection Capacity Analysis
 8: Anne Street N & South Access

25 Gouldie Street
 Total (2027) - PM

						
Movement	WBL	WBR	NBT	NBR	SBL	SBT
Lane Configurations						
Traffic Volume (veh/h)	7	1	215	10	1	184
Future Volume (Veh/h)	7	1	215	10	1	184
Sign Control	Stop		Free			Free
Grade	0%		0%			0%
Peak Hour Factor	0.92	0.92	0.92	0.92	0.92	0.92
Hourly flow rate (vph)	8	1	234	11	1	200
Pedestrians						
Lane Width (m)						
Walking Speed (m/s)						
Percent Blockage						
Right turn flare (veh)						
Median type	None			None		
Median storage veh						
Upstream signal (m)						
pX, platoon unblocked						
vC, conflicting volume	442	240			245	
vC1, stage 1 conf vol						
vC2, stage 2 conf vol						
vCu, unblocked vol	442	240			245	
tC, single (s)	6.4	6.2			4.1	
tC, 2 stage (s)						
tF (s)	3.5	3.3			2.2	
p0 queue free %	99	100			100	
cM capacity (veh/h)	573	799			1321	
Direction, Lane #	WB 1	NB 1	SB 1			
Volume Total	9	245	201			
Volume Left	8	0	1			
Volume Right	1	11	0			
cSH	592	1700	1321			
Volume to Capacity	0.02	0.14	0.00			
Queue Length 95th (m)	0.4	0.0	0.0			
Control Delay (s)	11.2	0.0	0.0			
Lane LOS	B		A			
Approach Delay (s)	11.2	0.0	0.0			
Approach LOS	B					
Intersection Summary						
Average Delay			0.2			
Intersection Capacity Utilization			21.9%	ICU Level of Service	A	
Analysis Period (min)			15			

Appendix F – Transportation Tomorrow Survey Excerpt



TTS Cross Tabulation

Cross Tabulation Query Form - Trip - 2016

Filter Variables

Group Attributes

Grouping file: No file chosen

Filter Selection +

2006 GTA zone of household In 8516

 Trip purpose of destination In W, R

 Start time of trip In 700-900

Output

Comma-delimited table
 Column format

Wed May 01 2024 10:10:27 GMT-0400 (Eastern Daylight Time) - Run Time: 2632ms

Cross Tabulation Query Form - Trip - 2016

Row: 2006 GTA zone of destination - gta06_dest
 Column: 2006 GTA zone of household - gta06_hhld

Filters:
 (2006 GTA zone of household - gta06_hhld In 8516
 and
 Trip purpose of destination - purp_dest In W, R,
 and
 Start time of trip - start_time In 700-900)

Trip 2016
 Table:

```

,8516
8501,88
8506,43
8507,8
8509,84
8512,14
8514,16
8515,16
8517,22
8521,33
8524,8
8526,32
8527,47
8554,38
8559,66
8560,28
8592,43
8595,43
8636,44
8643,38
  
```

Wed May 01 2024 10:10:27 GMT-0400 (Eastern Daylight Time) - Run Time: 2632ms

Cross Tabulation Query Form - Trip - 2016

Row: 2006 GTA zone of destination - gta06_dest

Column: 2006 GTA zone of household - gta06_hhld

Filters:

(2006 GTA zone of household - gta06_hhld In 8516

and

Trip purpo: R

and

Start time of trip - start_time In 700-900)

Trip 2016

Table:

TO (Destin	FROM (Origin)									Comments	Total check
	8516	Trip %	Destination	North via Anne	South via Anne	West via Neelands	North via Anne	South via Anne	West via Neelands		
8501	88	12.38%	Barrie E	0%	100%	0%	0.00%	12.38%	0.00%		100.00%
8506	43	6.05%	Barrie E	0%	100%	0%	0.00%	6.05%	0.00%		100.00%
8507	8	1.13%	Barrie E	0%	100%	0%	0.00%	1.13%	0.00%		100.00%
8509	84	11.81%	Barrie E	0%	100%	0%	0.00%	11.81%	0.00%		100.00%
8512	14	1.97%	Barrie NE	10%	90%	0%	0.20%	1.77%	0.00%		100.00%
8514	16	2.25%	Barrie N	10%	90%	0%	0.23%	2.03%	0.00%		100.00%
8515	16	2.25%	Barrie N	10%	90%	0%	0.23%	2.03%	0.00%		100.00%
8517	22	3.09%	Barrie W	10%	80%	10%	0.31%	2.48%	0.31%		100.00%
8521	33	4.64%	Barrie SW	10%	80%	10%	0.46%	3.71%	0.46%		100.00%
8524	8	1.13%	Barrie S	0%	95%	5%	0.00%	1.07%	0.06%		100.00%
8526	32	4.50%	Barrie SE	0%	95%	5%	0.00%	4.28%	0.23%		100.00%
8527	47	6.61%	Barrie SE	0%	95%	5%	0.00%	6.28%	0.33%		100.00%
8554	38	5.34%	Essa	0%	95%	5%	0.00%	5.08%	0.27%		100.00%
8559	66	9.28%	Innisfil	0%	95%	5%	0.00%	8.82%	0.46%		100.00%
8560	28	3.94%	Innisfil	0%	95%	5%	0.00%	3.74%	0.20%		100.00%
8592	43	6.05%	Springwater	85%	15%	0%	5.14%	0.91%	0.00%		100.00%
8595	43	6.05%	Innisfil	0%	95%	5%	0.00%	5.75%	0.30%		100.00%
8636	44	6.19%	Bradford west Gwillimbury	0%	95%	5%	0.00%	5.88%	0.31%		100.00%
8643	38	5.34%	Springwater	85%	15%	0%	4.54%	0.80%	0.00%		100.00%
TOTAL	711	100.00%					11.00%	86.00%	3.00%		
							100.00%				

Appendix G – MTO Left Turn Analysis

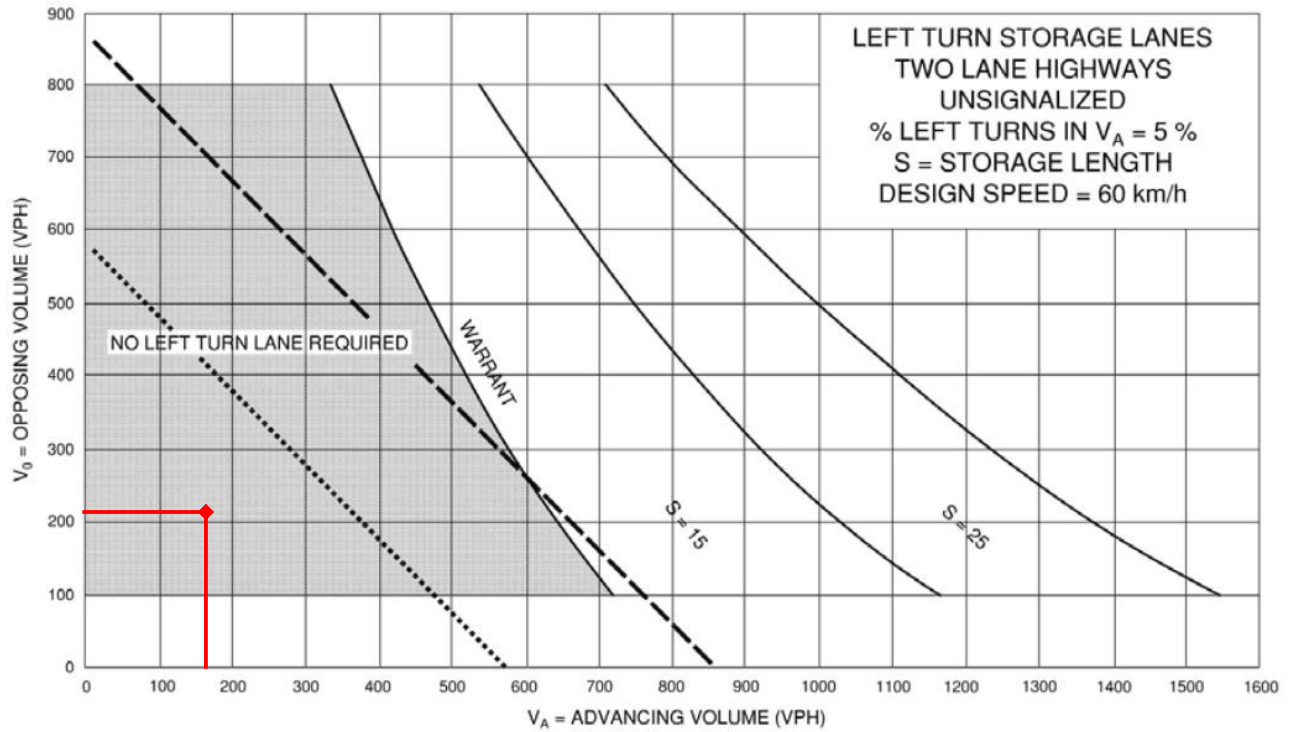

Total (2027) PM Peak – SB on North Access / Anne Street North

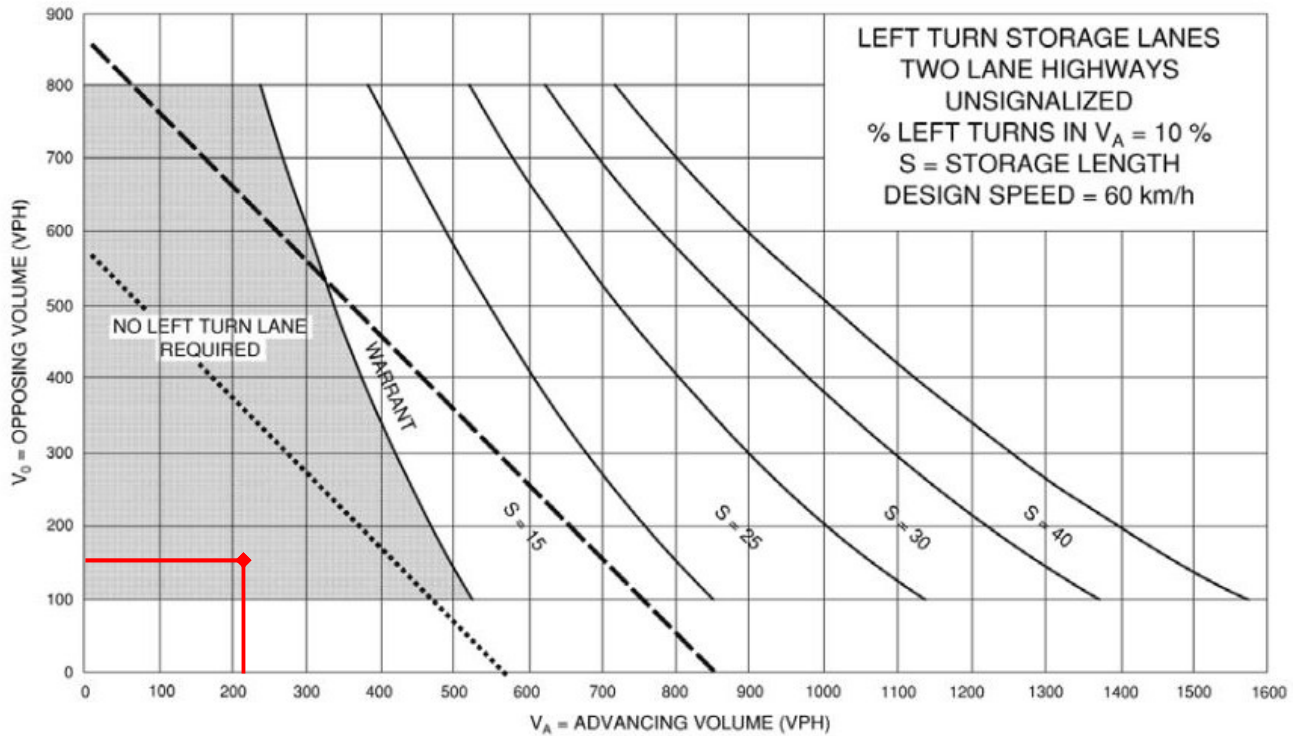

Total (2027) PM Peak – NB on North Access / Anne Street North

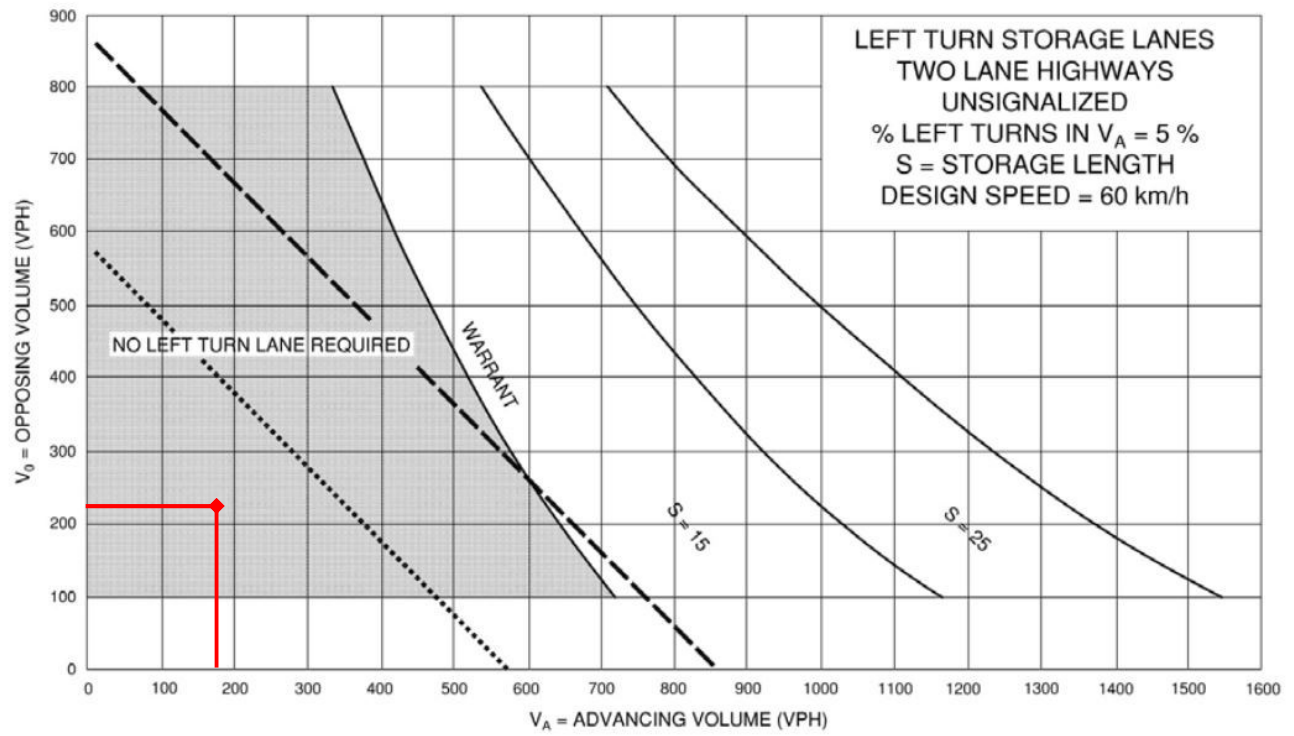

Total (2027) PM Peak – SB on South Access/ Anne Street North

Appendix H – OTM Signal Justification Sheets

Justification No. 7 - Total (2027) Traffic

Anne Street North / North Access

Justification	Description	Rest. Flow	Compliance		Entire %	Signal Warrant	Underground Provisions Warrant
			Sectional				
			Numerical	%			
1. Minimum Vehicular Volume	A. Vehicle volume, all approaches (average hour)	720	173	24%	11%	NO	NO
	B. Vehicle volume, along minor streets (average hour)	170	22	13%		NO	NO
2. Delay to cross traffic	A. Vehicle volume, major street (average hour)	720	139	19%	10%	NO	NO
	B. Combined vehicle and pedestrian volume crossing artery from minor streets (average hour)	75	9	12%		NO	NO

Justification No. 7 - Total (2027) Traffic

Anne Street North / South Access

Justification	Description	Rest. Flow	Compliance		Entire %	Signal Warrant	Underground Provisions Warrant
			Sectional				
			Numerical	%			
1. Minimum Vehicular Volume	A. Vehicle volume, all approaches (average hour)	720	174	24%	1%	NO	NO
	B. Vehicle volume, along minor streets (average hour)	255	5	2%		NO	NO
2. Delay to cross traffic	A. Vehicle volume, major street (average hour)	720	166	23%	4%	NO	NO
	B. Combined vehicle and pedestrian volume crossing artery from minor streets (average hour)	75	5	6%		NO	NO

Appendix I – Swept Path Analysis

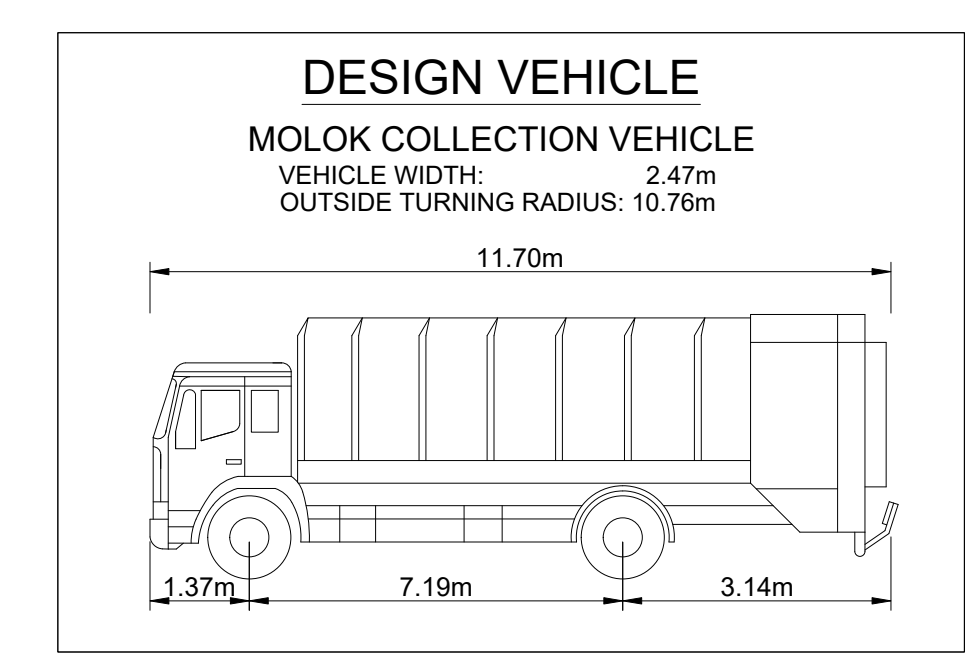
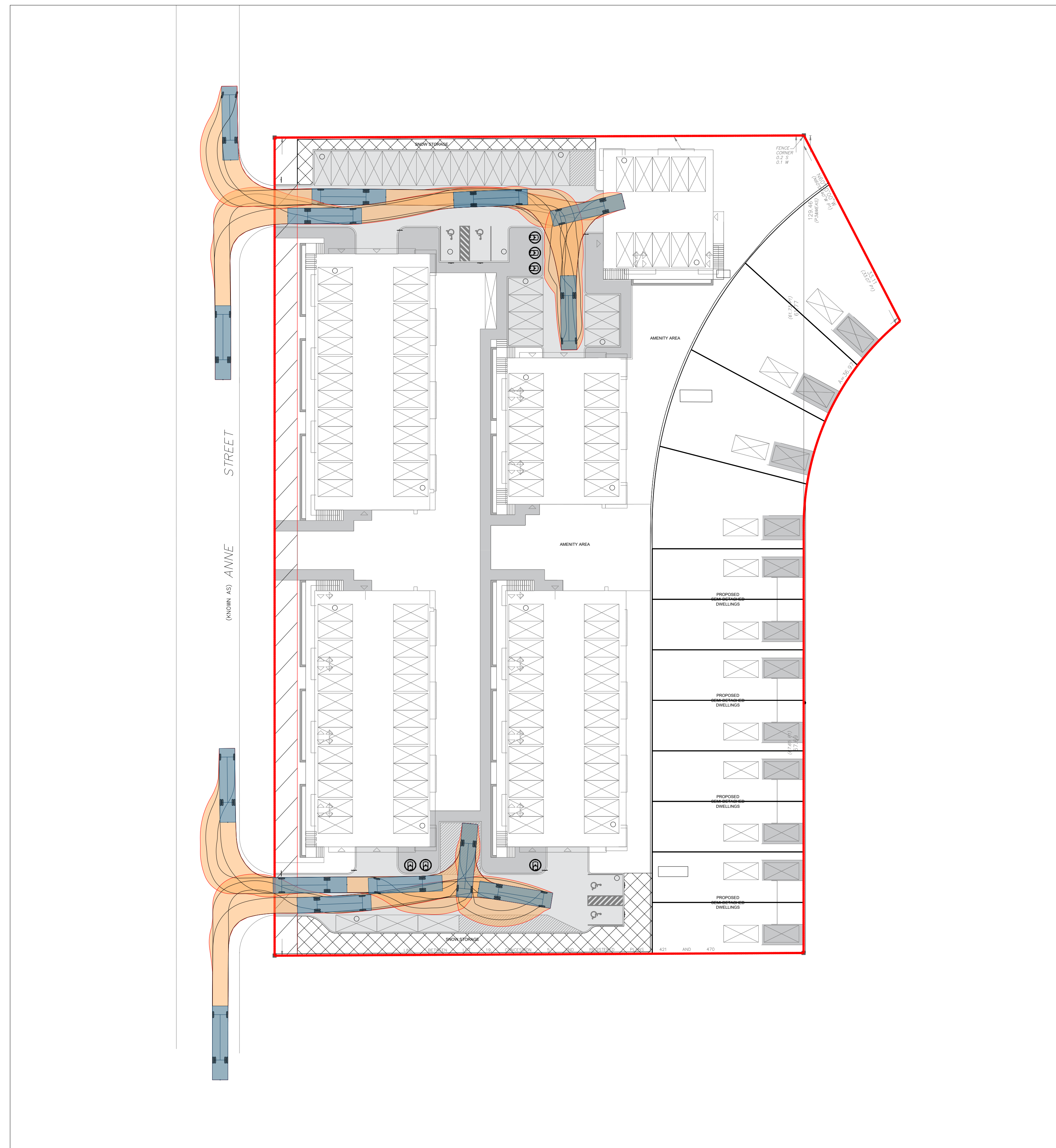
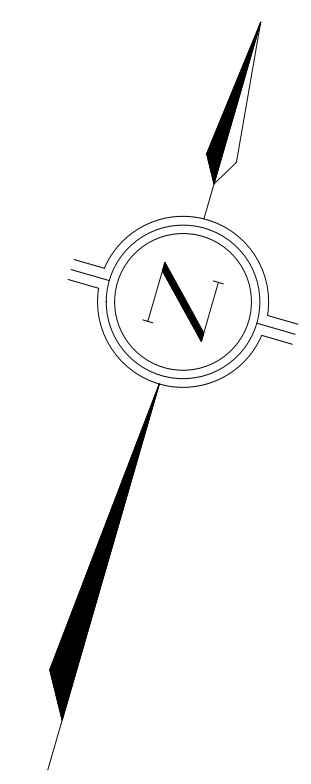

GENERAL NOTES
 1. THIS DRAWING IS NOT INTENDED FOR CONSTRUCTION.
 2. DO NOT SCALE DRAWINGS.
 3. THE DRAWINGS ARE THE PROPERTY OF JD ENGINEERING AND MUST BE RETURNED ON COMPLETION OF THE PROJECT.
 4. BASE DRAWING PROVIDED BY IPS INC. ON JANUARY 9TH, 2025.

NO.	DATE	APPROVED	REVISIONS
2.	JAN 2025	JN	SECOND SUBMISSION
1.	DEC 2022	JN	FIRST SUBMISSION

JD Northcote Engineering Inc.
 Phone: 705.725.4035
 86 Cumberland Street
 Barrie, ON L4N 2P6
 www.JDEngineering.ca

PROJECT
435 ANNE STREET

CLIENT
WYNSTAR ANNE STREET LP INC.

DRAWING TITLE
VEHICLE SWEEP PATH REVIEW

SUBTITLE
MOLOK WASTE COLLECTION VEHICLE

DESIGN: RH	DATE: 01/25
DRAWN: RH	DATE: 01/25
REVIEWED: RHJ	DATE: 01/25
SCALE HOR: 1:400	SCALE VERT: N/A
SHEET NO: 22087 - TURN-1	

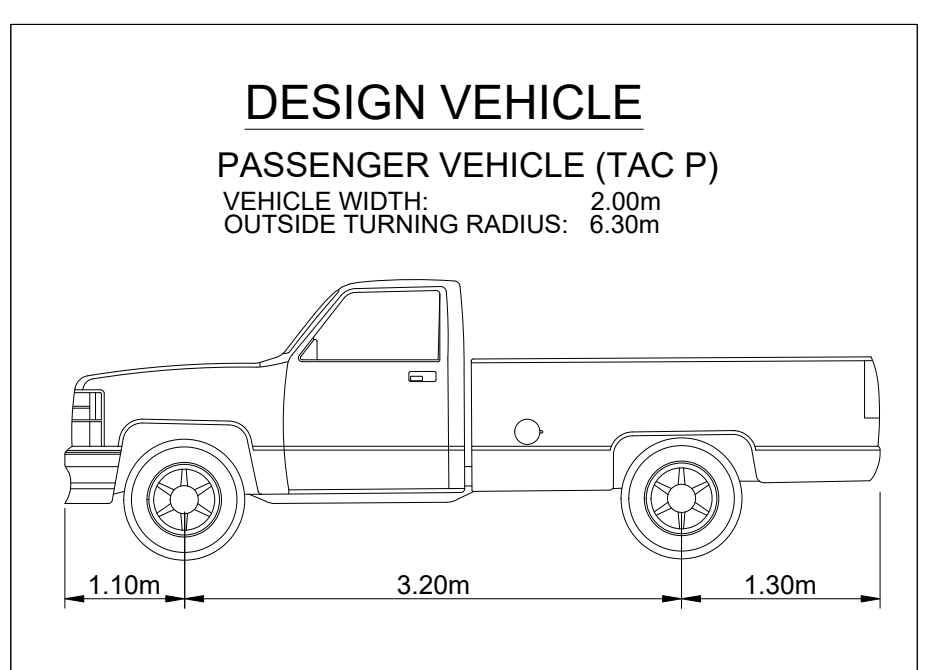
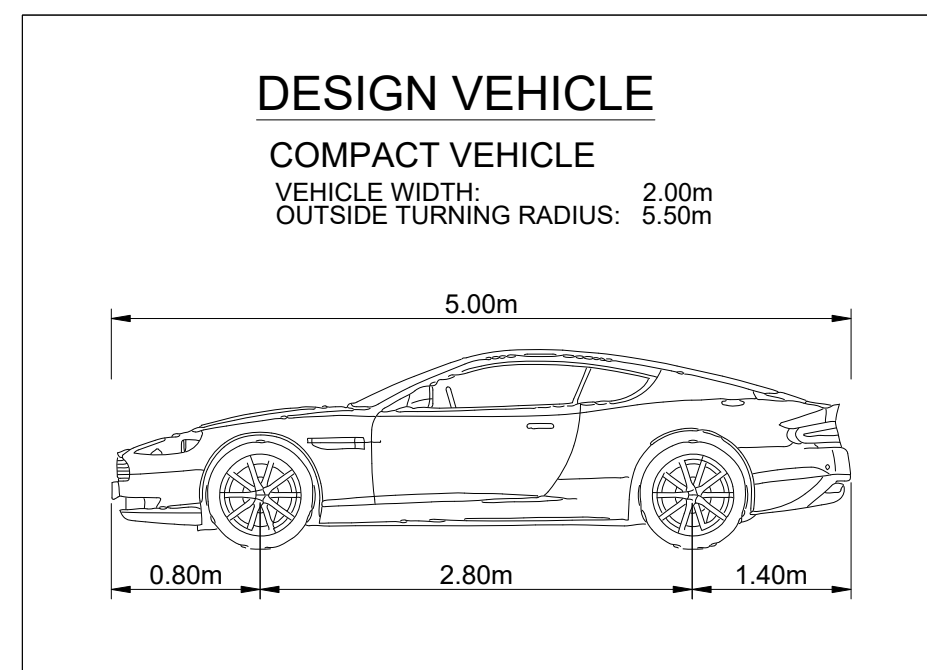
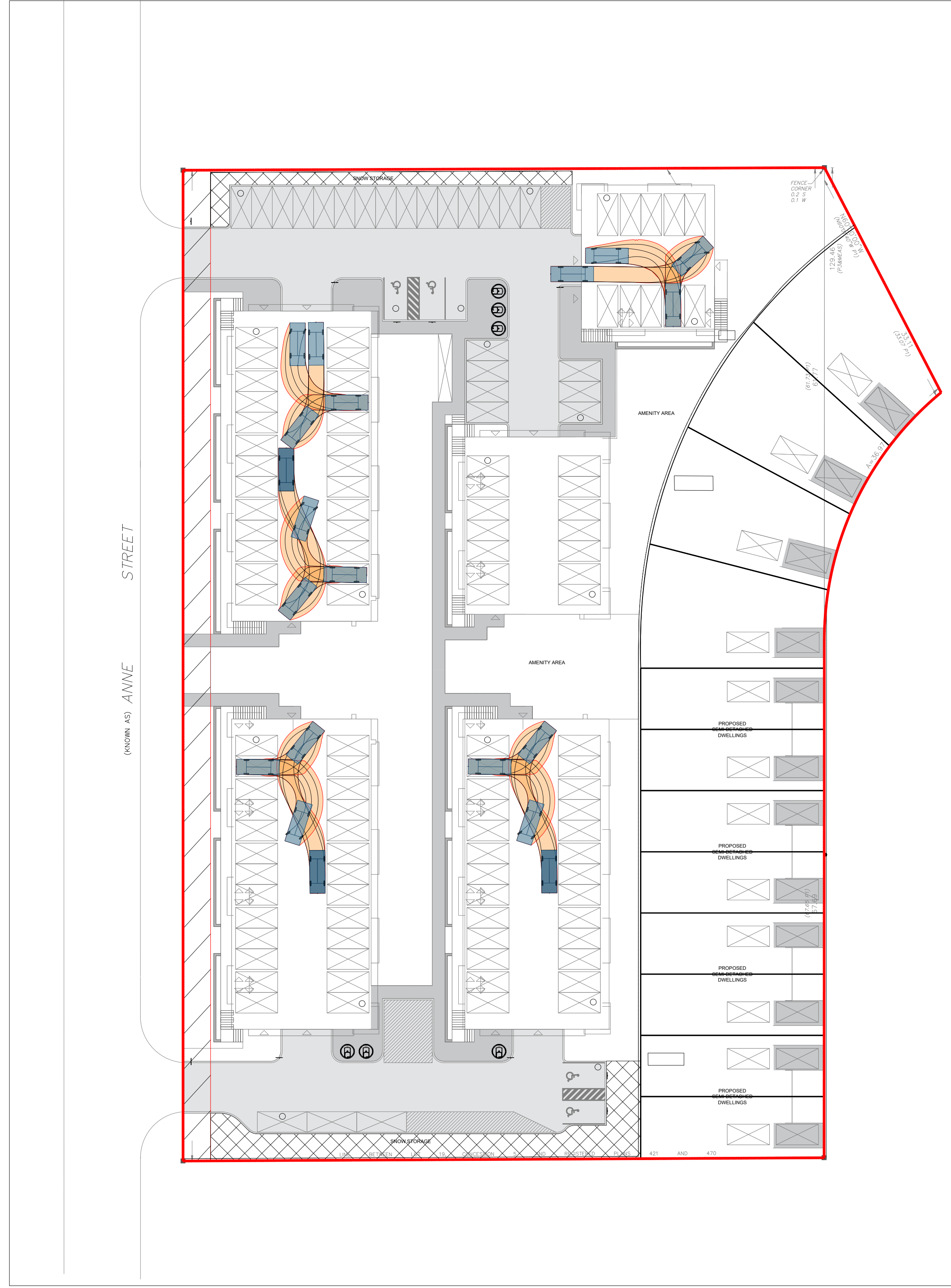
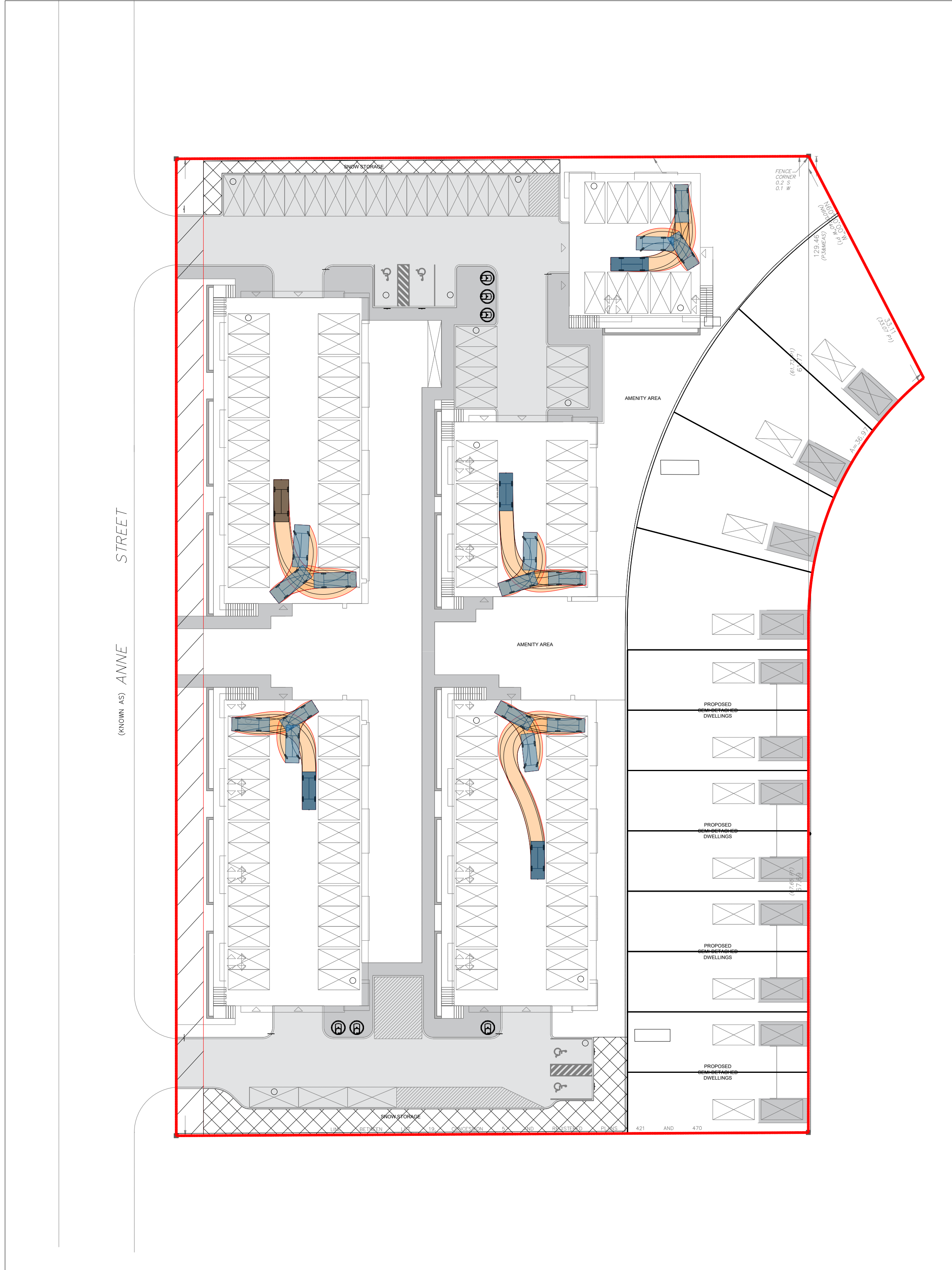
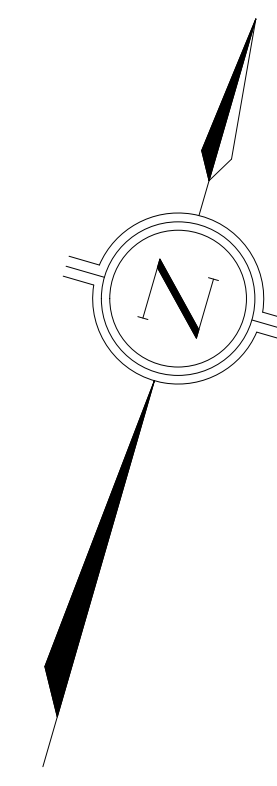

GENERAL NOTES
 1. THIS DRAWING IS NOT INTENDED FOR CONSTRUCTION.
 2. DO NOT SCALE DRAWINGS.
 3. THE DRAWINGS ARE THE PROPERTY OF JD ENGINEERING AND MUST BE RETURNED ON COMPLETION OF THE PROJECT.
 4. BASE DRAWING PROVIDED BY RAW DESIGN ON JANUARY 2ND, 2025.

NO.	DATE	APPROVED	REVISIONS
2.	JAN 2025	JN	SECOND SUBMISSION
1.	DEC 2022	JN	FIRST SUBMISSION

JD Northcote Engineering Inc.
 Phone: 705.725.4035
 86 Cumberland Street
 Barrie, ON L4N 2P6
 www.JDEngineering.ca

PROJECT
162-182 NORFOLK AVENUE

CLIENT
NORFOLK DEVELOPMENTS INC.

DRAWING TITLE
VEHICLE SWEEP PATH REVIEW

SUBTITLE
**TAC PASSENGER VEHICLE
 COMPACT VEHICLE**

DESIGN: JN	DATE: 01/25
DRAWN: JN	DATE: 01/25
REVIEWED: JN	DATE: 01/25
SCALE HOR: 1:400	SCALE VERT: N/A
SHEET NO. 22038 - TURN-2	

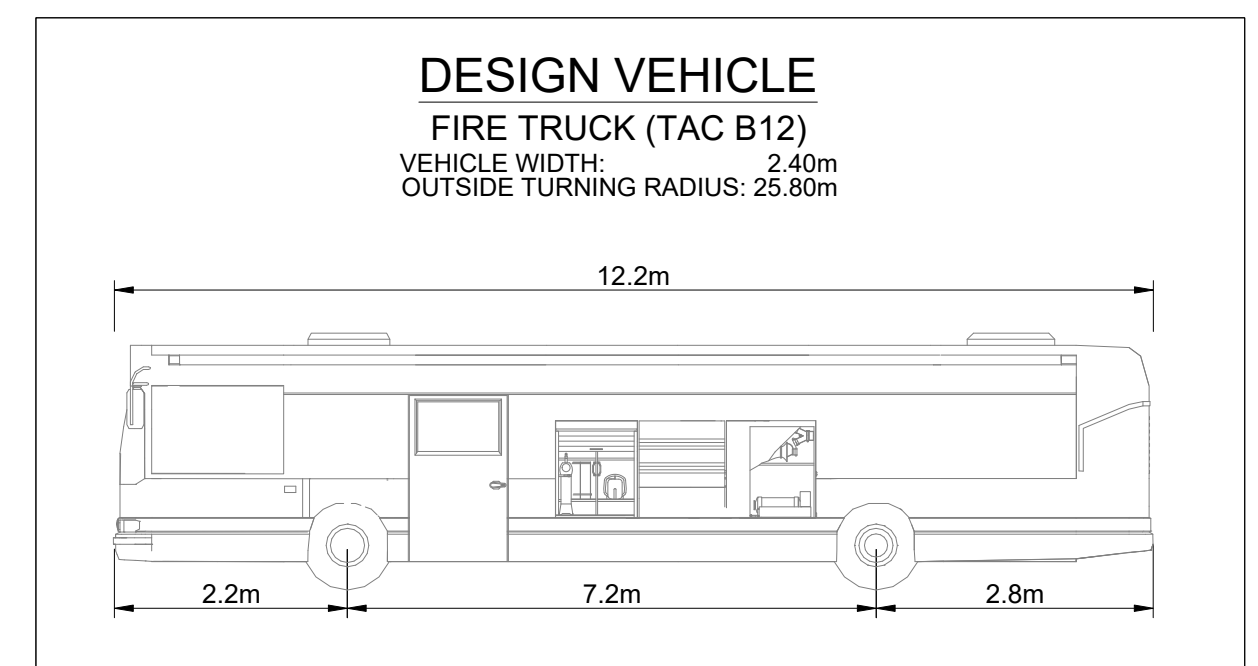
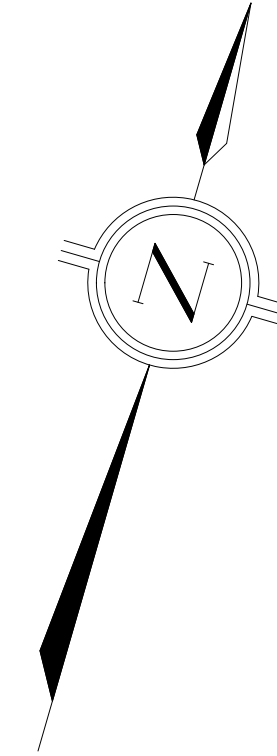
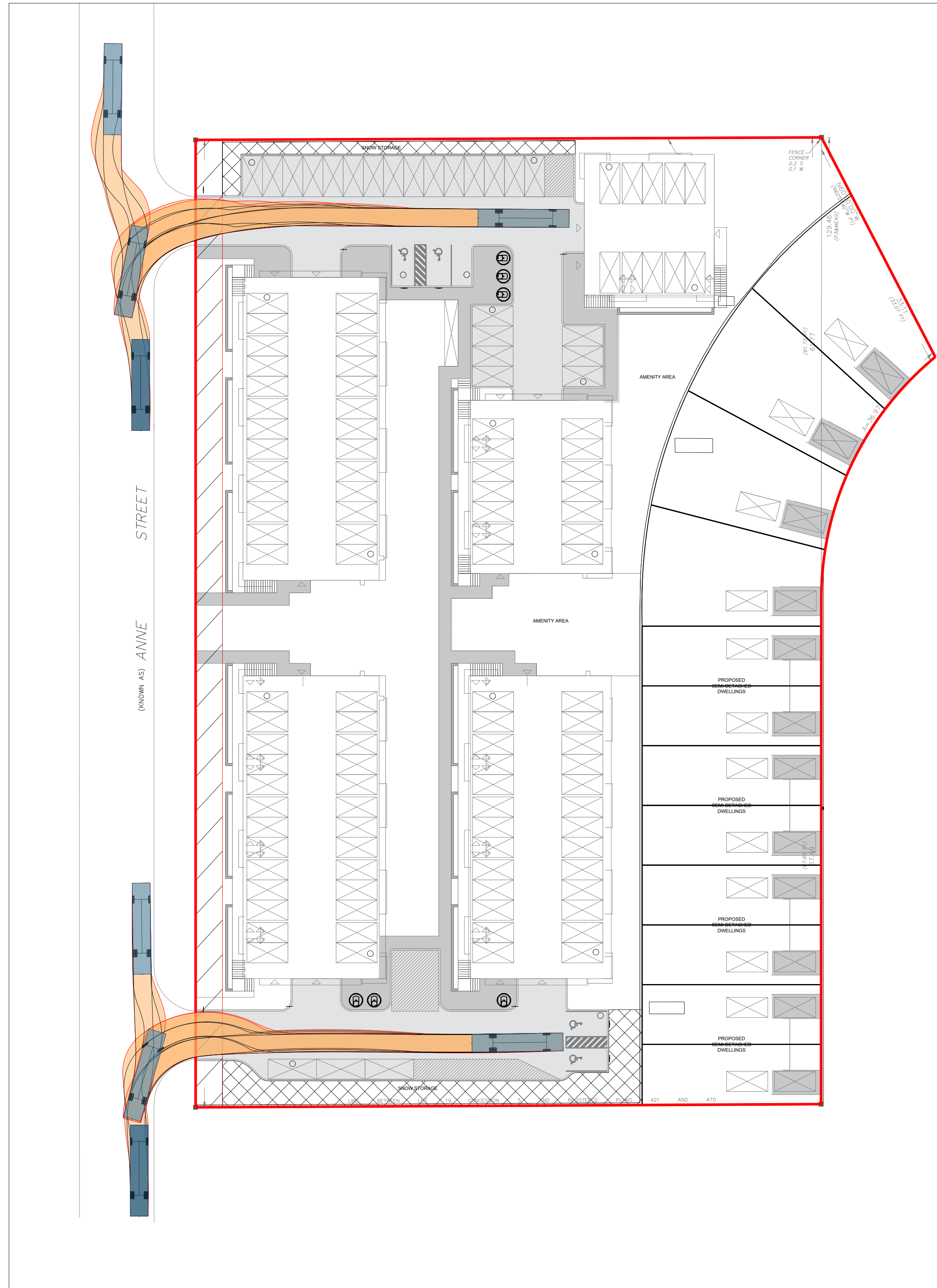

GENERAL NOTES
 1. THIS DRAWING IS NOT INTENDED FOR CONSTRUCTION.
 2. DO NOT SCALE DRAWINGS.
 3. THE DRAWINGS ARE THE PROPERTY OF JD ENGINEERING AND MUST BE RETURNED ON COMPLETION OF THE PROJECT.
 4. BASE DRAWING PROVIDED BY RAW DESIGN ON JANUARY 2ND, 2025.

NO.	DATE	APPROVED	REVISIONS
2.	JAN 2025	JN	SECOND SUBMISSION
1.	DEC 2022	JN	FIRST SUBMISSION

JD Northcote Engineering Inc.
 Phone: 705.725.4035
 86 Cumberland Street
 Barrie, ON L4N 2P6
 www.JDEngineering.ca

PROJECT
162-182 NORFOLK AVENUE

CLIENT
NORFOLK DEVELOPMENTS INC.

DRAWING TITLE
VEHICLE SWEEP PATH REVIEW

SUBTITLE
**EMERGENCY VEHICLE
 (FIRE TRUCK (TAC B12))**

DESIGN: JN	DATE: 01/25
DRAWN: JN	DATE: 01/25
REVIEWED: JN	DATE: 01/25
SCALE HOR: 1:400	SCALE VERT: N/A
SHEET NO. 22038 - TURN-3	