

THE GEORGIAN APARTMENTS 290, 294, 298, & 302 GEORGIAN DRIVE

DRAWING LIST:

ND-1	NOTES AND DETAILS
SG-1	SITE GRADING PLAN
SS-1	SITE SERVICING PLAN
STM-1	PRE-DEVELOPMENT CATCHMENT PLAN
STM-2	POST-DEVELOPMENT CATCHMENT PLAN
EPR-1	EROSION PROTECTION AND REMOVALS PLAN

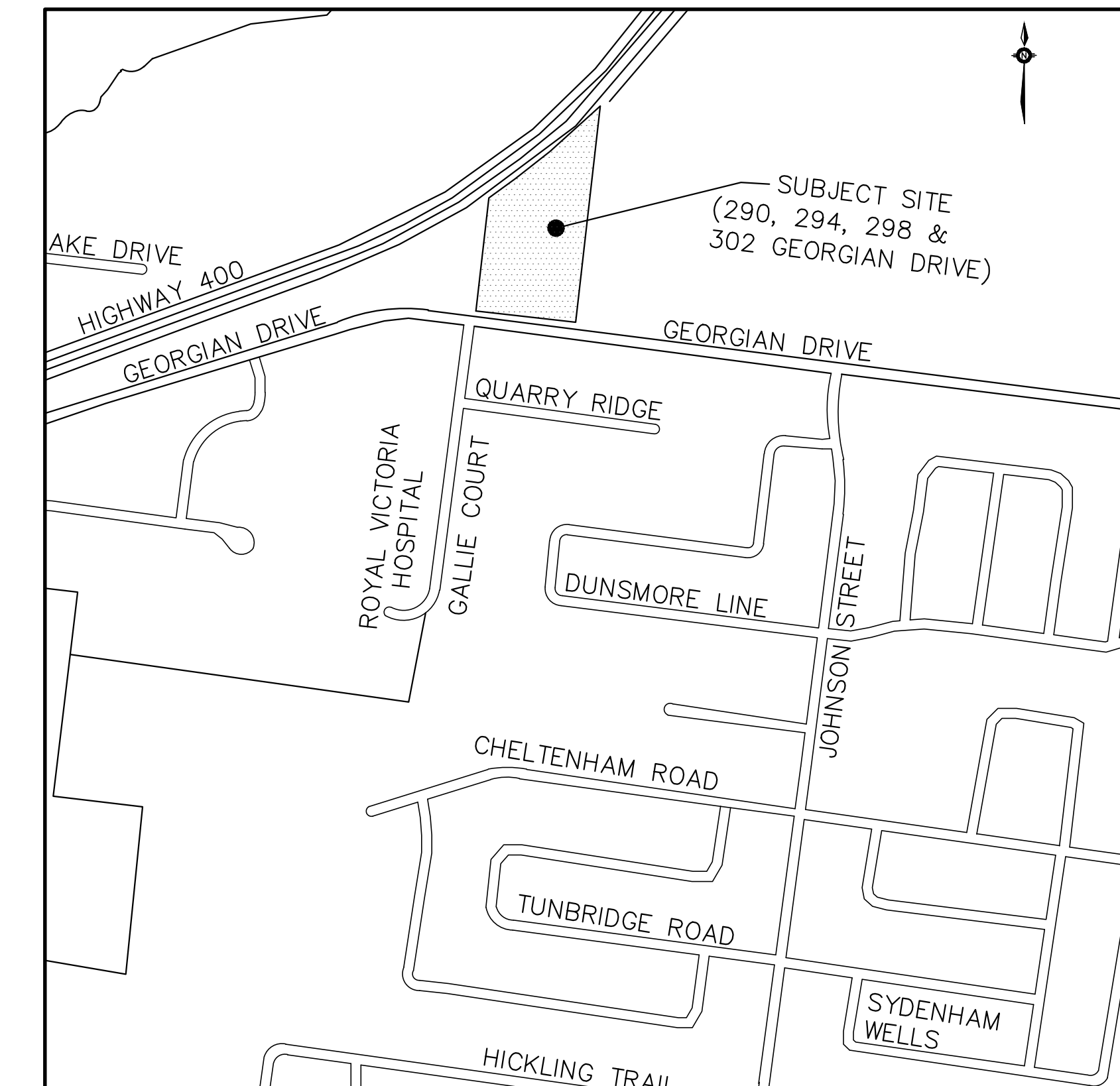

CITY OF BARRIE
70 COLLIER ST.
BARRIE, ON
L4M 4T5

ATRIA DEVELOPMENT
6 CARLAW AVE. SUITE 200
TORONTO, ON
M4M 2R5



PEARSON
ENGINEERING
PEARSONENG.COM PH. 705.719.4785

GENERAL NOTES

- 1. DRAWINGS**
 - A. ALL DRAWINGS SHALL BE PRODUCED IN ACCORDANCE WITH CURRENT CITY OF BARRIE STANDARDS & SYMBOLS FOR PLAN & PROFILE DRAWINGS, GENERAL SERVICE PLANS AND LOT GRADING PLANS.
- 2. MEASUREMENTS**
 - A. ALL DIMENSIONS ARE IN METRES, EXCEPT PIPE DIAMETERS, WHICH ARE IN MILLIMETRES, UNLESS SPECIFIED OTHERWISE.
- 3. GENERAL**
 - A. ALL WORK SHALL BE IN ACCORDANCE WITH CURRENT CITY OF BARRIE STANDARD DRAWINGS (BSD) AND ONTARIO PROVINCIAL STANDARD DRAWINGS (OPSD).
 - B. ORDER OF PRECEDENCE OF STANDARD DRAWINGS IS FIRSTLY CITY OF BARRIE STANDARD DRAWINGS (BSD) AND SECONDLY ONTARIO PROVINCIAL STANDARD DRAWINGS (OPSD).
 - C. LOCATION OF EXISTING SERVICES ARE NOT GUARANTEED. THE CONTRACTOR IS REQUIRED TO NOTIFY THE VARIOUS UTILITY COMPANIES 48 HOURS PRIOR TO THE COMMENCEMENT OF ANY WORK.
 - D. A ROAD OCCUPANCY PERMIT IS REQUIRED FROM THE ROADS AND PARKS OPERATIONS BRANCH PRIOR TO THE COMMENCEMENT OF WORK WITHIN ANY CITY RIGHT-OF-WAY.
 - E. A SITE ALTERATION PERMIT IS REQUIRED FROM THE ENGINEERING DEPARTMENT PRIOR TO THE COMMENCEMENT OF ANY EARTH WORKS ON THE SITE.
 - F. NATIVE MATERIAL, SUITABLE FOR BACKFILL, SHALL BE COMPACTED TO 95% STANDARD PROCTOR MAXIMUM DRY DENSITY.
 - G. GRANULAR MATERIAL, USED FOR BACKFILL, SHALL BE PLACED IN LAYERS 150mm IN DEPTH MAXIMUM AND COMPACTED TO 100% STANDARD PROCTOR MAXIMUM DRY DENSITY.
 - H. ALL DISTURBED AREAS ARE TO BE REINSTATED TO THEIR ORIGINAL CONDITION OR BETTER, AS DETERMINED BY THE CITY ENGINEERING DEPARTMENT.
 - I. ALL SILT CONTROL AND EROSION PROTECTION DEVICES ARE TO BE IN PLACE PRIOR TO THE COMMENCEMENT OF CONSTRUCTION AND SHALL REMAIN IN PLACE AND BE MAINTAINED BY THE CONTRACTOR UNTIL CONSTRUCTION IS COMPLETE AND THE GRASS HAS ESTABLISHED GROWTH, SUBJECT TO APPROVAL BY THE CITY ENGINEERING DEPARTMENT.
 - J. ALL EXISTING WELLS AND/OR BOREHOLES EQUIPPED WITH PEIZOMETERS ARE TO BE DECOMMISSIONED AS PER M.O.E. GUIDELINES AND PRACTICES. (O.REG 903)

GENERAL NOTES - ROADWORKS

- SINGLE - STAGE CURB & GUTTER TO COMPLY WITH OPSD 600.040**
- INTERNAL SITE CURBS ARE TO BE BARRIER CURBS AS PER OPSD 600.110**
- SIDEWALKS TO COMPLY WITH OPSD-310.010 AND ARE TO BE 1.5 METRES WIDE. MINIMUM THICKNESS AS FOLLOWS:**
 - RESIDENTIAL DRIVEWAY 150mm
 - COMMERCIAL/INDUSTRIAL DRIVEWAY 200mm (REINFORCEMENT AS PER OPSD IF REQUIRED)
 - WHEN NO DRIVEWAY IS PRESENT, 125mm.
- NATIVE SUBGRADE SHALL HAVE A CROSSFALL OF 3% AND THE MATERIAL SHALL BE APPROVED BY A SOILS CONSULTANT AND IS SUBJECT TO APPROVAL BY THE DIRECTOR OF ENGINEERING.**
- NATIVE SUBGRADE TO BE COMPACTED TO MINIMUM 95% STANDARD PROCTOR MAXIMUM DRY DENSITY AND SHALL BE PROOF ROLLED.**
- GRADE AND CROSS FALL ADJUSTMENT OF MAINTENANCE HOLE AND CATCH BASIN FRAMES WILL BE MADE USING PRODUCTS SPECIFICALLY MANUFACTURED FOR THAT PURPOSE. THE TOP ADJUSTMENT UNIT OF ALL CATCH BASIN AND MAINTENANCE HOLES SHALL BE RUBBER.**
- ADJUSTMENT UNITS MUST BE CERTIFIED TO MEET ALL PERTINENT OPS, CSA, ASTM AND MTO-DSM LIST, OR OTHER INDUSTRY GUIDELINES FOR MATERIALS, PERFORMANCE AND USE AS APPLICABLE.**
- ADJUSTMENT UNITS AND JOINTS WILL BE SEALED AND OR PARGED IN COMPLIANCE WITH MANUFACTURERS SPECIFICATIONS AND GUIDELINES.**
- MORTAR IS USED FOR LEVELING OF PRECAST UNITS ONLY. THE THICKNESS OF MORTAR WILL BE 10mm TO FILL ALL VOIDS CREATED BY IRREGULARITIES IN THE PRECAST UNITS TO ENSURE AN EVEN SURFACE ONLY.**
- NON-COMPRESSIBLE BACK FILL WILL BE USED DURING REBUILDING, ADJUSTING, OR ANY OTHER APPLICABLE CATCH BASIN OR MAINTENANCE HOLE WORKS.**
- SIDEWALKS TO COMPLY WITH OPSD 310.010 AND ARE TO BE 1.5m WIDE. MINIMUM THICKNESS AS FOLLOWS:**
 - RESIDENTIAL DRIVEWAY, 150mm
 - COMMERCIAL DRIVEWAY, 200mm (REINFORCEMENT AS PER OPSD IF REQUIRED)
 - WHEN NO DRIVEWAY IS PRESENT, 125mm
- SIDEWALKS TO BE CONSTRUCTED ON 150mm GRANULAR "A" BEDDING UNLESS OTHERWISE SPECIFIED BY THE DIRECTOR OF PUBLIC WORKS.**
- CONCRETE BUS SHALL BE 200mm OF CONCRETE AND CONSTRUCTED ON 150mm GRANULAR "A" BEDDING**

GENERAL NOTES - STORM SEWER

- STORM SEWER TO BE PROVIDED ON ALL ROADS WITH CURB AND GUTTER.**
- PLACE ALL CATCH BASIN LATERALS AT 2% GRADE UNLESS OTHERWISE NOTED. PIPE SIZE MINIMUM 250mm DIA. SINGLE, 300mm DIA. DOUBLE.**
- STORM SEWERS SHALL BE CONSTRUCTED WITH BEDDING AS PER OPSD-802.010 (GRAN. 'A' EMBEDMENT MATERIAL) FOR FLEXIBLE PIPES AND OPSD-802.030 OR 802.031 CLASS B (GRAN. 'A' BEDDING MATERIAL) FOR RIGID PIPE UNLESS OTHERWISE APPROVED BY THE DIRECTOR OF ENGINEERING.**
- MAINTENANCE HOLE TOPS (FRAMES) AND CATCH BASIN (FRAMES) ARE TO BE SET TO BASE COURSE ASPHALT GRADE AND THEN ADJUSTED TO FINAL GRADE WHEN THE TOP LIFT OF ASPHALT IS PLACED. ALL ADJUSTMENT WILL BE ACCORDANCE WITH BSD-N2.**
- ALL CONNECTIONS TO THE STORM MAIN SHALL BE MADE WITH A STORM MANHOLE OR APPROVED FACTORY TEE CONNECTION AS PER OPSD-708.01 OR 708.03.**
- PIPE MATERIAL TO BE REINFORCED CONCRETE WITH A MINIMUM STRENGTH OF 50 N/m²mm CERTIFIED TO C.S.A. STANDARD A247.2-1982, CLASS 50-D (PREVIOUSLY C.S.A. STANDARD A257.2-1974, CLASS II) OR PVC CERTIFIED TO C.S.A. STANDARDS 182.2 AND 182.4.**
- STORM SEWER TO BE MINIMUM 300mm DIAMETER WITH JOINTS CONFORMING TO C.S.A. STANDARD A257.3, UNLESS OTHERWISE SPECIFIED.**
- ALL PIPE BEDDING MUST CONFORM TO OPSD, MAXIMUM COVER TABLE. NO FLEXIBLE PIPE SEWERS WILL BE INSTALLED WITH A DEPTH OF COVER GREATER THAN 6 METRES UNLESS SPECIFICALLY APPROVED BY THE DIRECTOR OF ENGINEERING.**
- ALL PIPE HANDLING INSTALLATIONS MUST BE IN STRICT COMPLIANCE WITH MANUFACTURERS INSTALLATION GUIDES AND THE O.C.P.A. OR UNIBELL GUIDELINES.**

GENERAL NOTES - SANITARY SEWER

- SANITARY SEWERS**
- ALL CONNECTIONS TO NEW SANITARY MAINS SHALL BE PRE-MANUFACTURED, FABRICATED TEES. CONNECTIONS TO EXISTING SANITARY SEWER SHALL BE MADE WITH APPROVED FACTORY MADE TEES.**
 - SEWERS SHALL BE CONSTRUCTED WITH BEDDINGS AS PER OPSD-802.010, (GRAN. 'A' EMBEDMENT MATERIAL) FOR FLEXIBLE PIPES AND OPSD-802.030 OR 802.031 CLASS B (GRAN. 'A' BEDDING MATERIAL) FOR RIGID PIPE UNLESS OTHERWISE APPROVED BY THE DIRECTOR OF ENGINEERING.**
 - MAXIMUM DEFLECTION FROM COMBINED LIVE AND DEAD LOADING SHALL NOT EXCEED ANY C.S.A., O.P.S. OR MANUFACTURERS RECOMMENDED SPECIFICATIONS.**
 - PVC, CONCRETE AND PROFILE WALL PVC SEWERS SHALL HAVE RUBBER GASKET TYPE JOINTS AND SHALL BE CERTIFIED TO CONFORM TO ALL APPLICABLE CURRENT C.S.A. SPECIFICATIONS.**
 - CONCRETE SANITARY SEWERS SHALL HAVE A MINIMUM STRENGTH OF 50 N/m²mm CONFORMING TO CSA STANDARD A257.2-1982, CLASS 50-D (PREVIOUSLY C.S.A. STANDARD A257.2-1974, CLASS II).**
 - MAINTENANCE HOLE TOPS (FRAMES) ARE TO BE SET TO BASE COURSE ASPHALT GRADE AND THEN ADJUSTED TO FINAL GRADE WHEN THE TOP LIFT OF ASPHALT IS PLACED. ALL ADJUSTMENT WILL BE ACCORDANCE WITH BSD-N2, OR INSERTA-TEES IN STRICT ACCORDANCE TO MANUFACTURERS GUIDELINES.**

GENERAL NOTES - WATERMAIN

- CONTRACTOR SHALL INFORM THE CITY OF BARRIE ENGINEERING DEPARTMENT A MINIMUM OF 48 HOURS IN ADVANCE OF THEIR INTENTIONS TO WORK.**
- OPERATION OF FIRE HYDRANTS AND VALVES ON POTABLE WATER BY OTHER THAN ENGINEERING DEPARTMENT IS PROHIBITED BY BY-LAW 1-88 AS AMENDED BY BY-LAW 99-290. THE CITY WILL SWAB, PRESSURE TEST, CHLORINATE AND FLUSH ALL NEW WATERMANS.**
- MINIMUM COVER OVER WATERMAIN TO BE 1.7m. THE MINIMUM HORIZONTAL SEPARATION BETWEEN WATERMAIN AND SEWERS TO BE 2.5m. WHERE WATERMAIN CONFLICTS WITH SEWER PIPES, DEFLECT WATERMAIN HORIZONTALLY OR VERTICALLY WHILE PROVIDING A MINIMUM OF 0.5m CLEARANCE BETWEEN WATERMAIN AND SEWERS. MAINTAIN MINIMUM DEPTH OF COVER AT ALL TIMES.**
- WATERMAIN SHALL BE CONSTRUCTED WITH BEDDINGS AS PER OPSD 802.010 (GRANULAR 'A' EMBEDMENT MATERIAL) FOR FLEXIBLE PIPES AND OPSD 802.030 OR 802.031 CLASS 'B' (GRANULAR 'A' BEDDING MATERIAL, GRANULAR 'A' OR SELECT NATIVE COVER MATERIAL) FOR RIGID PIPE UNLESS OTHERWISE APPROVED BY THE DIRECTOR OF ENGINEERING, OR * ALTERNATIVE * ALTERNATIVE EMBEDMENT MATERIAL - SAND MEETING GRADATION REQUIREMENTS OF OPS 1004.05.05 COMPACTED TO 95% PROCTOR DENSITY, GEOTECHNICAL CERTIFICATION OF MATERIAL AND COMPACTION TESTING MUST BE PROVIDED EVERY 150 METRES. THE COMPACTION TESTING MUST INCLUDE THE ENTIRE EMBEDMENT ENVELOPE (HAUNCHES, BEDDING AND TOP OF PIPE).**
 - E. 2) COPPER WATER MAINS AND SERVICES 19mm to 50mm IN DIAMETER SHALL BE EMBEDDED IN SAND 100mm ABOVE AND BELOW TO CONFORM TO OPSD 1004.05.05.
- CONCRETE THRUST BLOCKS ARE TO BE INSTALLED AT ALL TEES, BENDS, HYDRANTS, END OF MAINS AND CONNECTIONS 100mm AND LARGER AS PER OPSD 1103.010 AND 1103.020. RESTRAINING DEVICES MAY BE REQUIRED IN ADDITION TO STANDARD CONCRETE THRUST BLOCKING WHERE SOIL CONDITIONS WARRANT.**
- RESTRAINING WILL BE REQUIRED ON ALL FIRE HYDRANTS**
- NEW WATERMANS TO BE PVC DR18 CL150, OR DUCTILE IRON CL52**
- TRACING WIRE (#12 TW) STRANDED COPPER) TO BE INSTALLED ON THE TOTAL LENGTH OF ALL NON-METALLIC WATERMAIN AND BROUGHT UP AT EACH HYDRANT AND CONNECTED TO FLANGE BOLT.**
- ALL WATER SERVICES SHALL BE MINIMUM 19mm TYPE 'K' COPPER UNLESS OTHERWISE APPROVED BY THE DIRECTOR OF ENGINEERING. WATER SERVICE SADDLES SHALL BE USED WHEN TAPPING INTO PVC WATERMAIN.**
- RISER PIPES ARE TO BE INSTALLED AS PER BSD-45 (REV. #1), AND REMOVED AS DIRECTED. SWABBING SCHEDULE TO BE SUPPLIED BY A CITY OF BARRIE FIELD REPRESENTATIVE.**
- SERVICE TAPPINGS SHALL BE PLACED AT A MINIMUM SEPARATION OF 1.0m AND A MINIMUM OF 0.6m FROM JOINTS. (ENDS OF PIPE)**

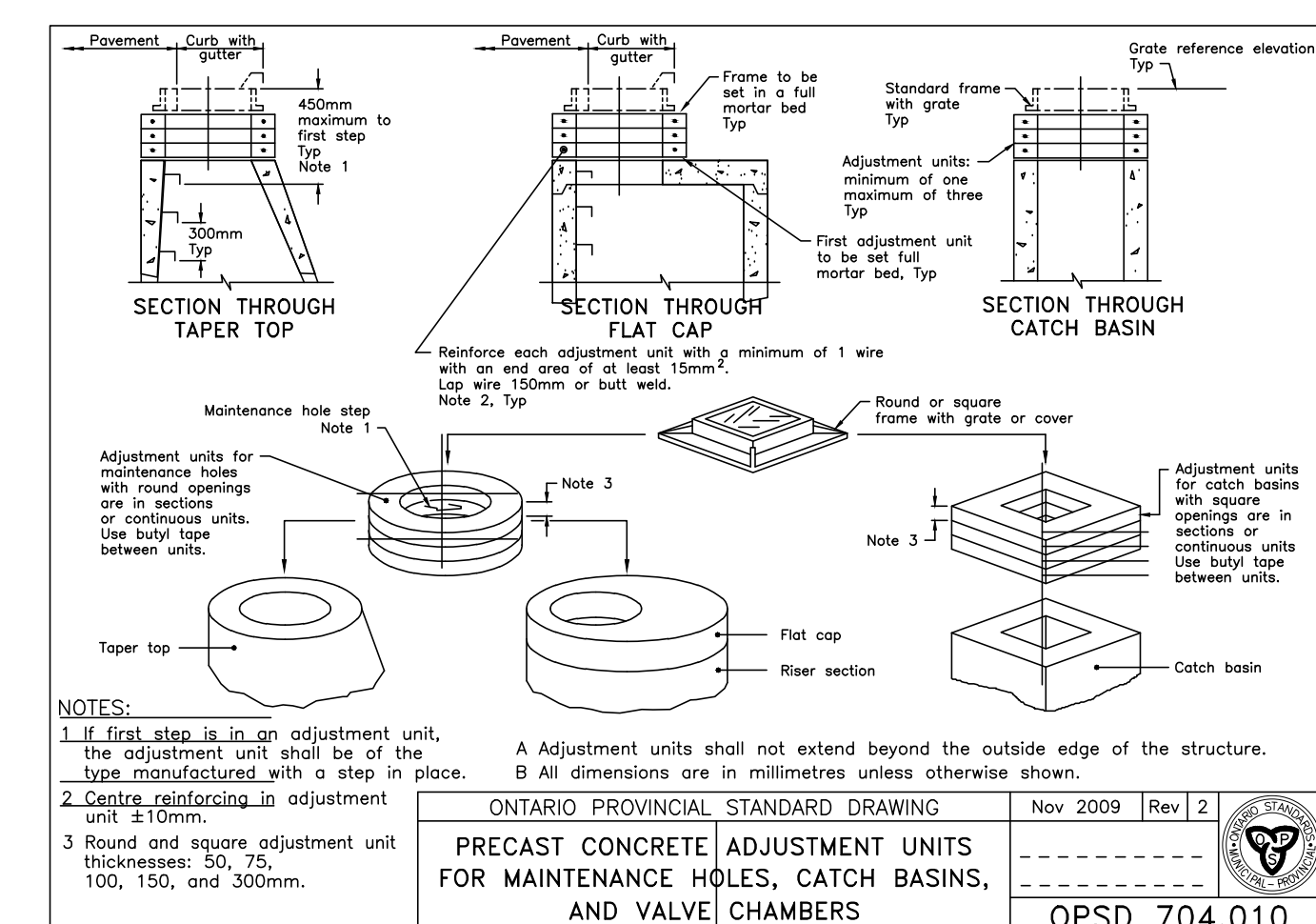
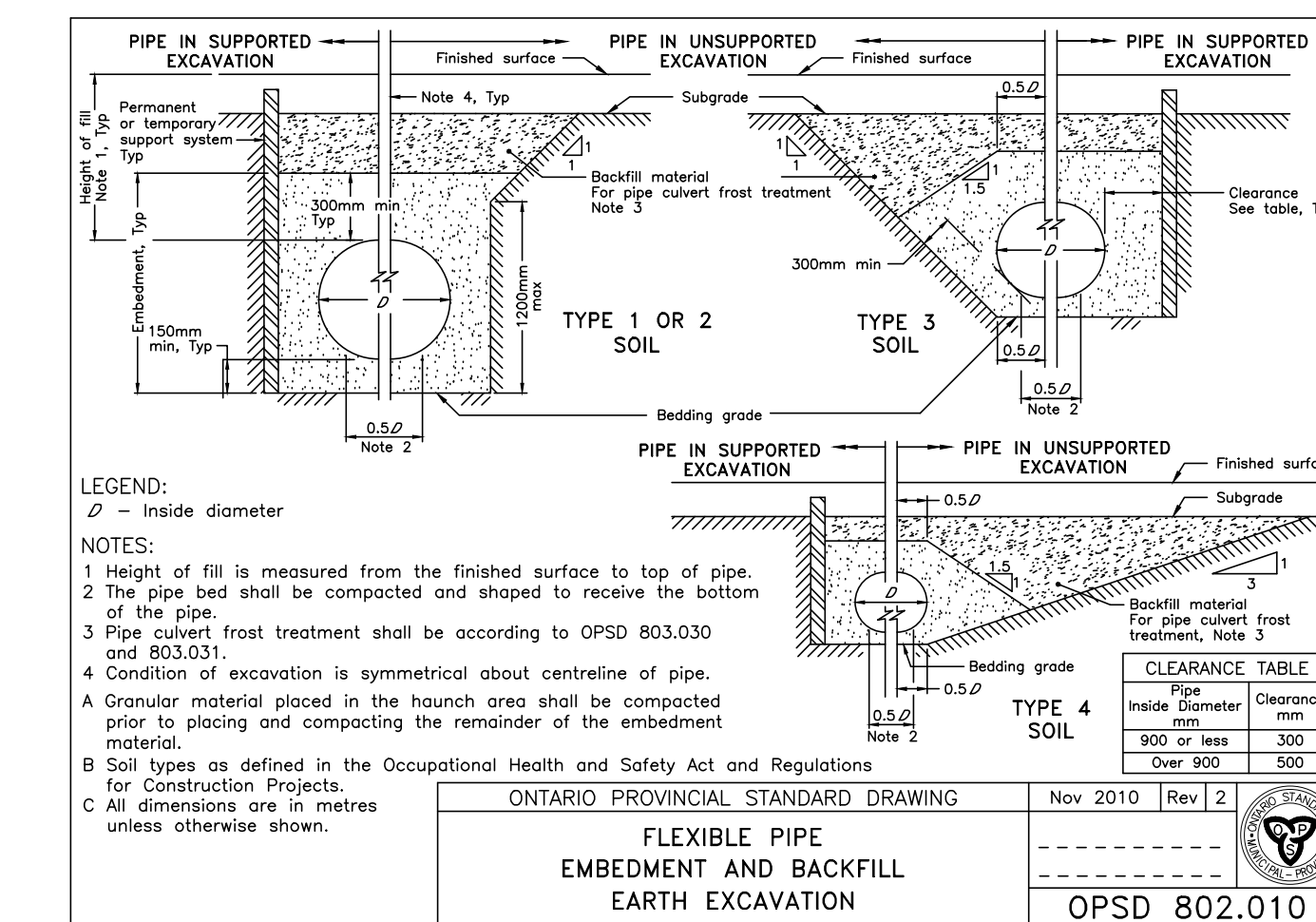
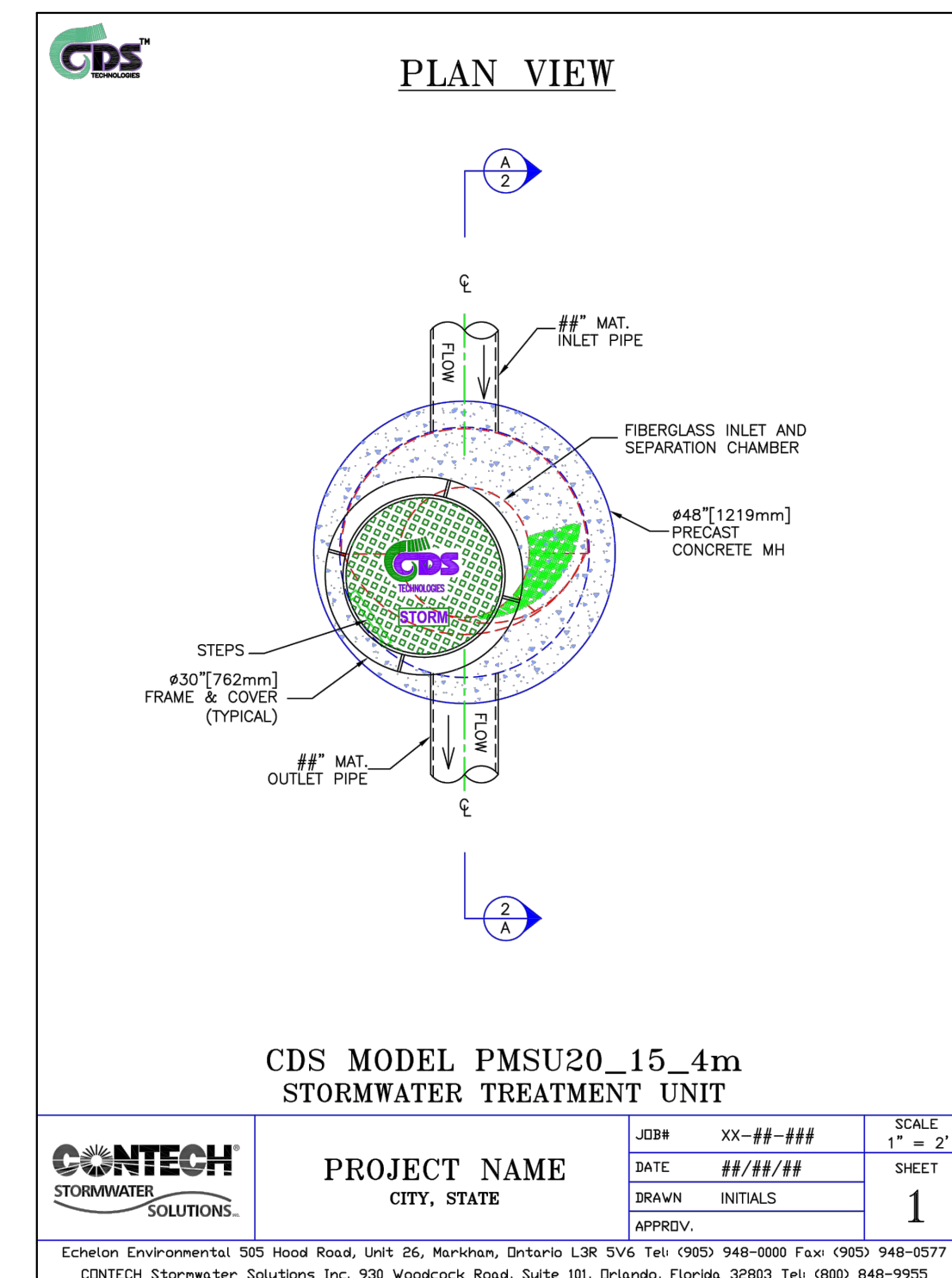
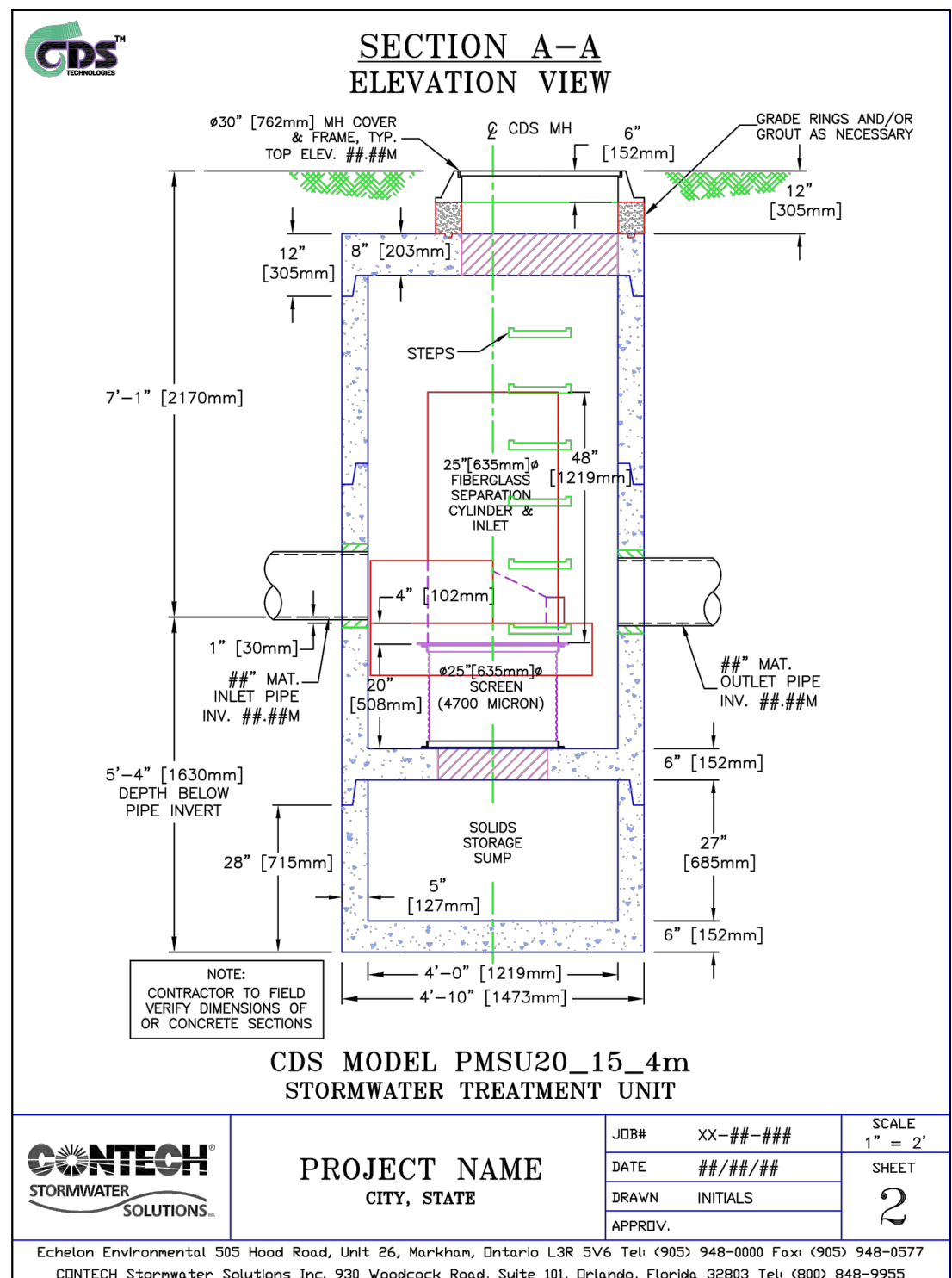
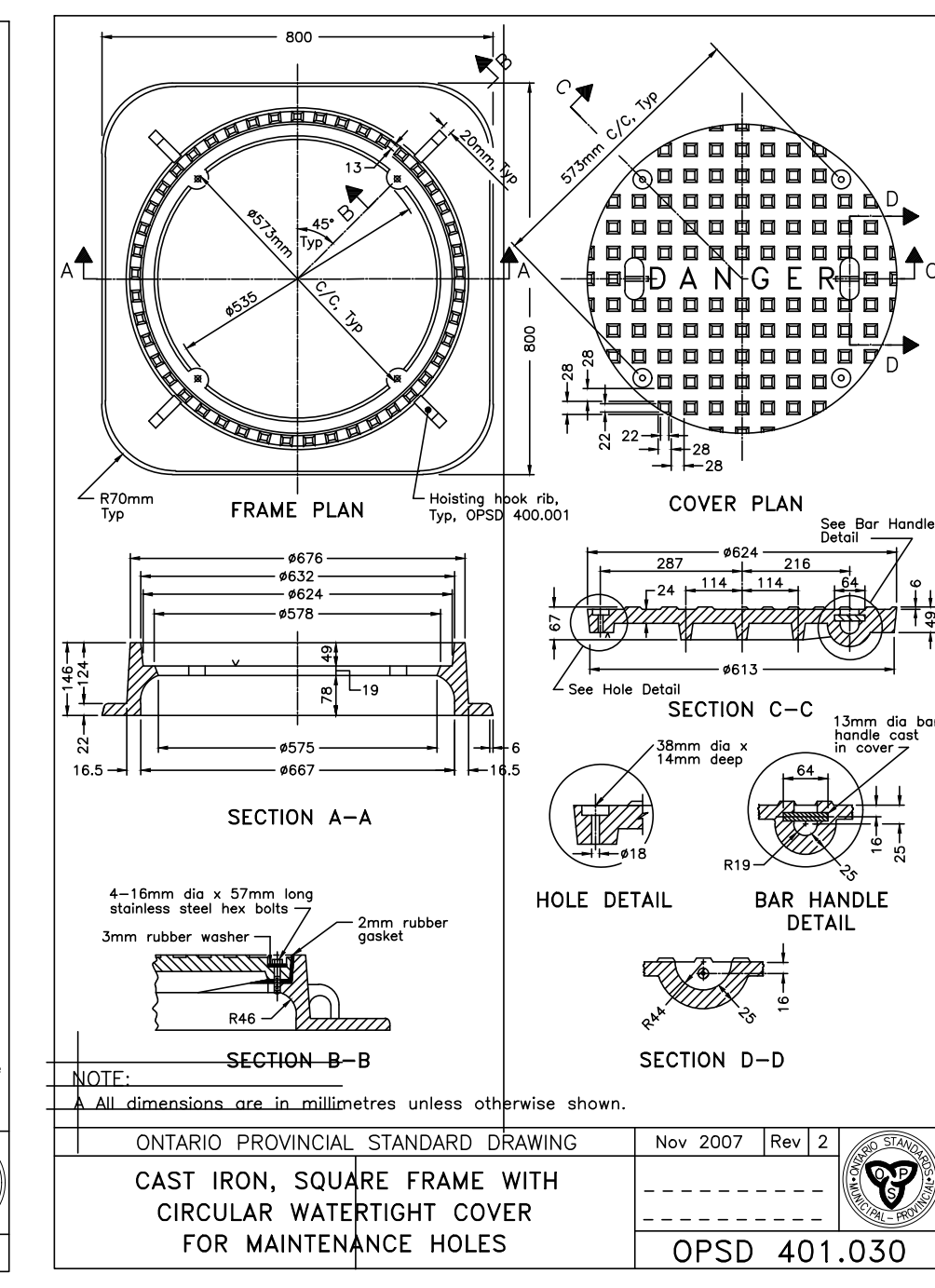
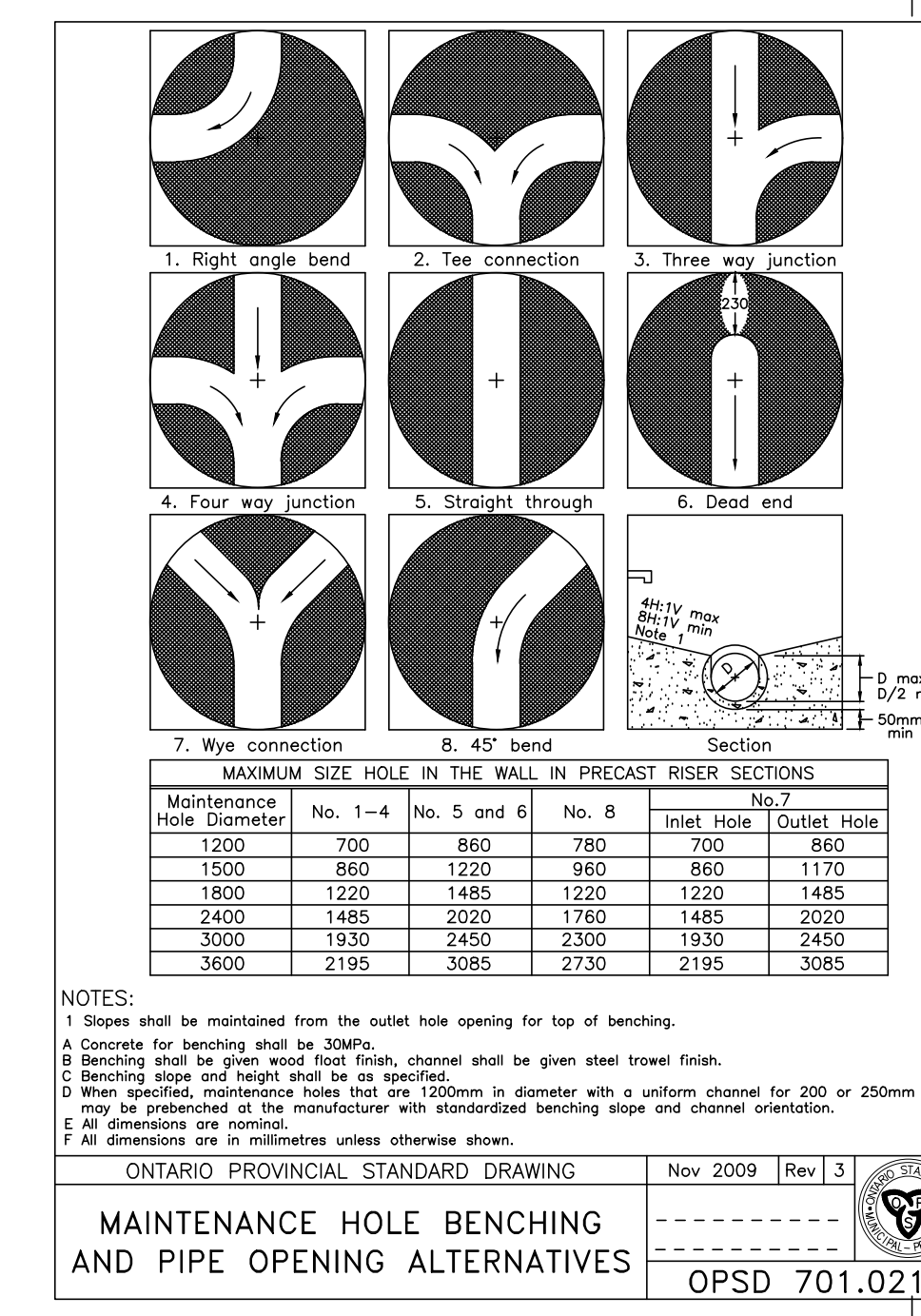
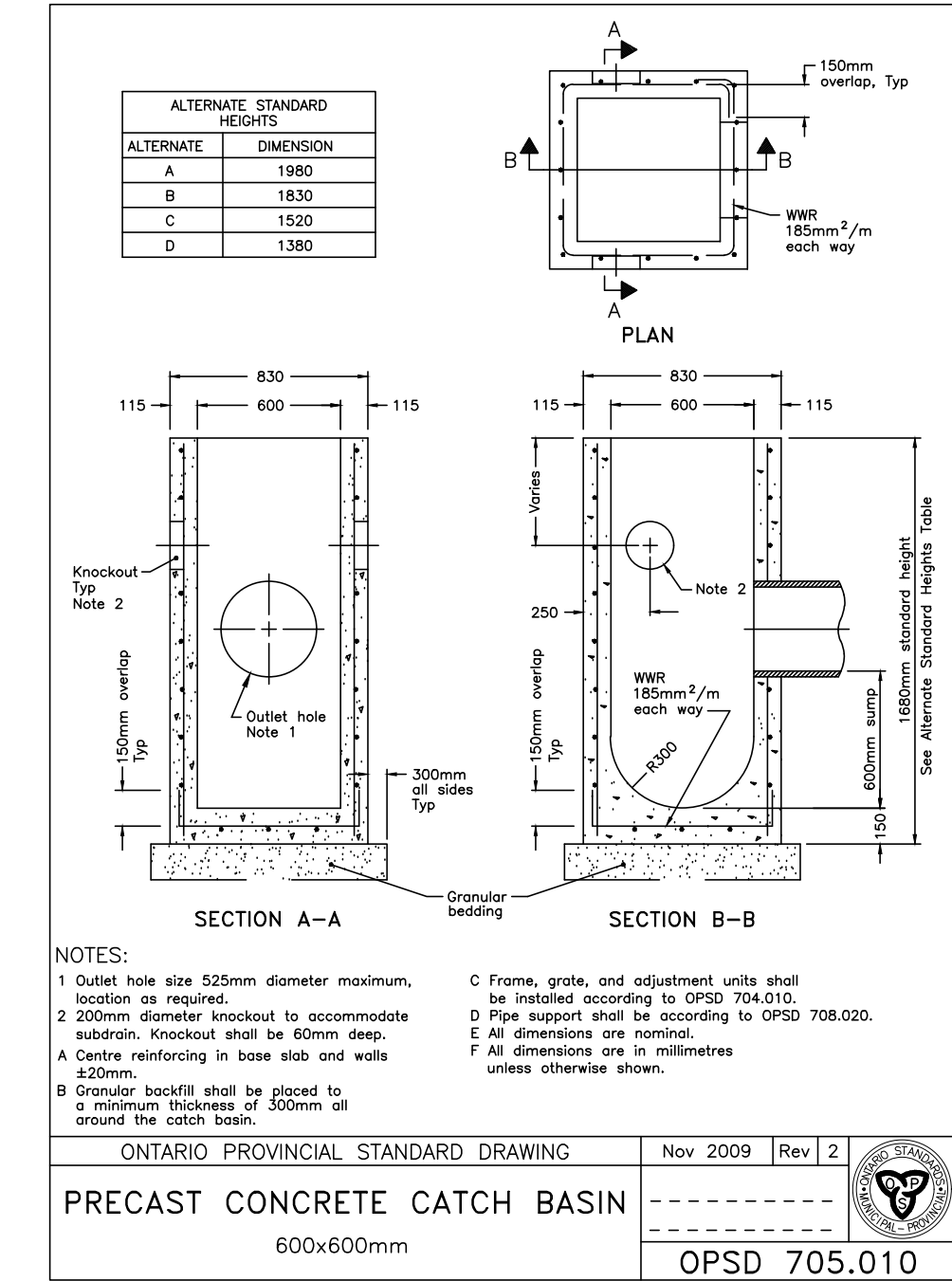
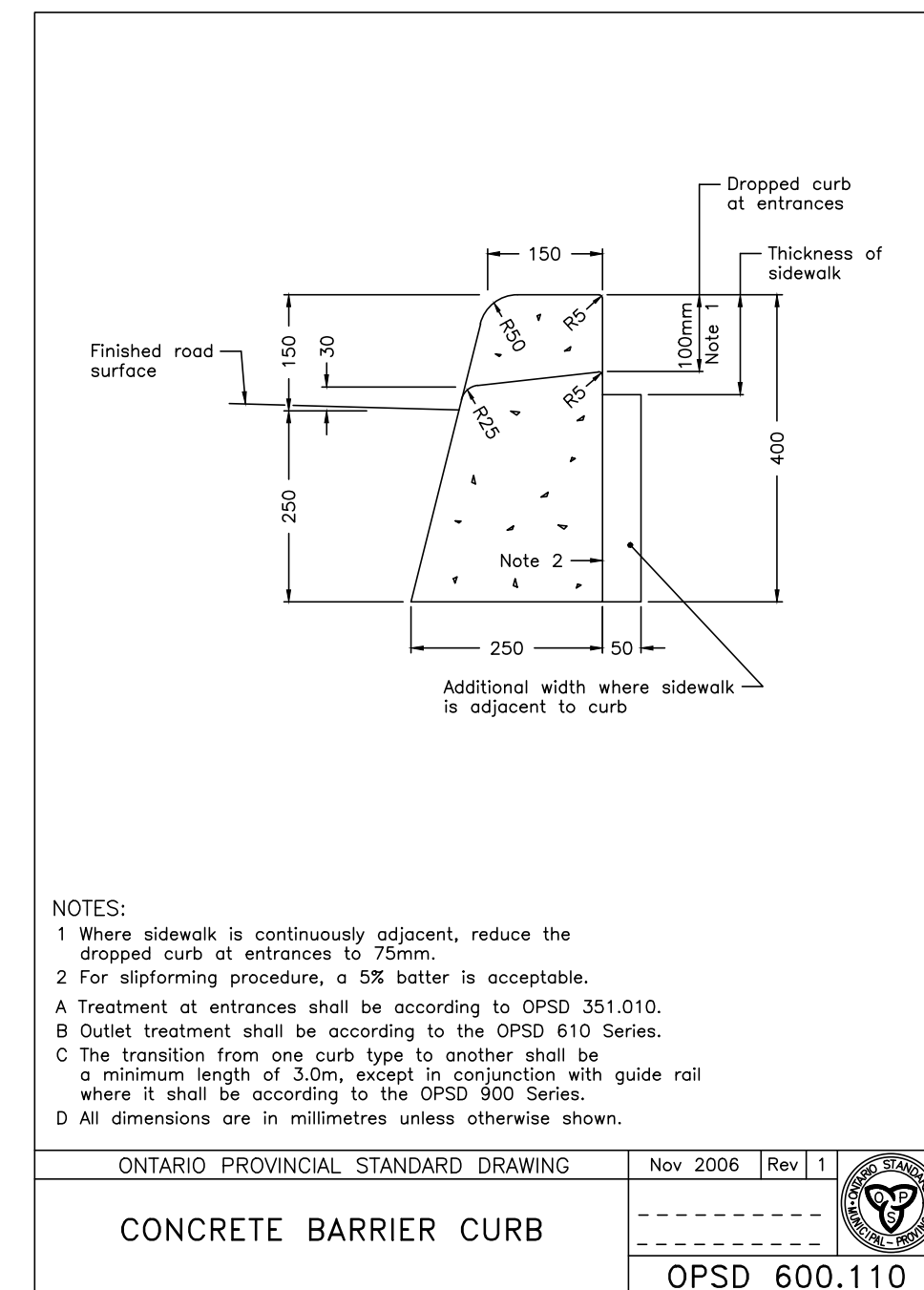
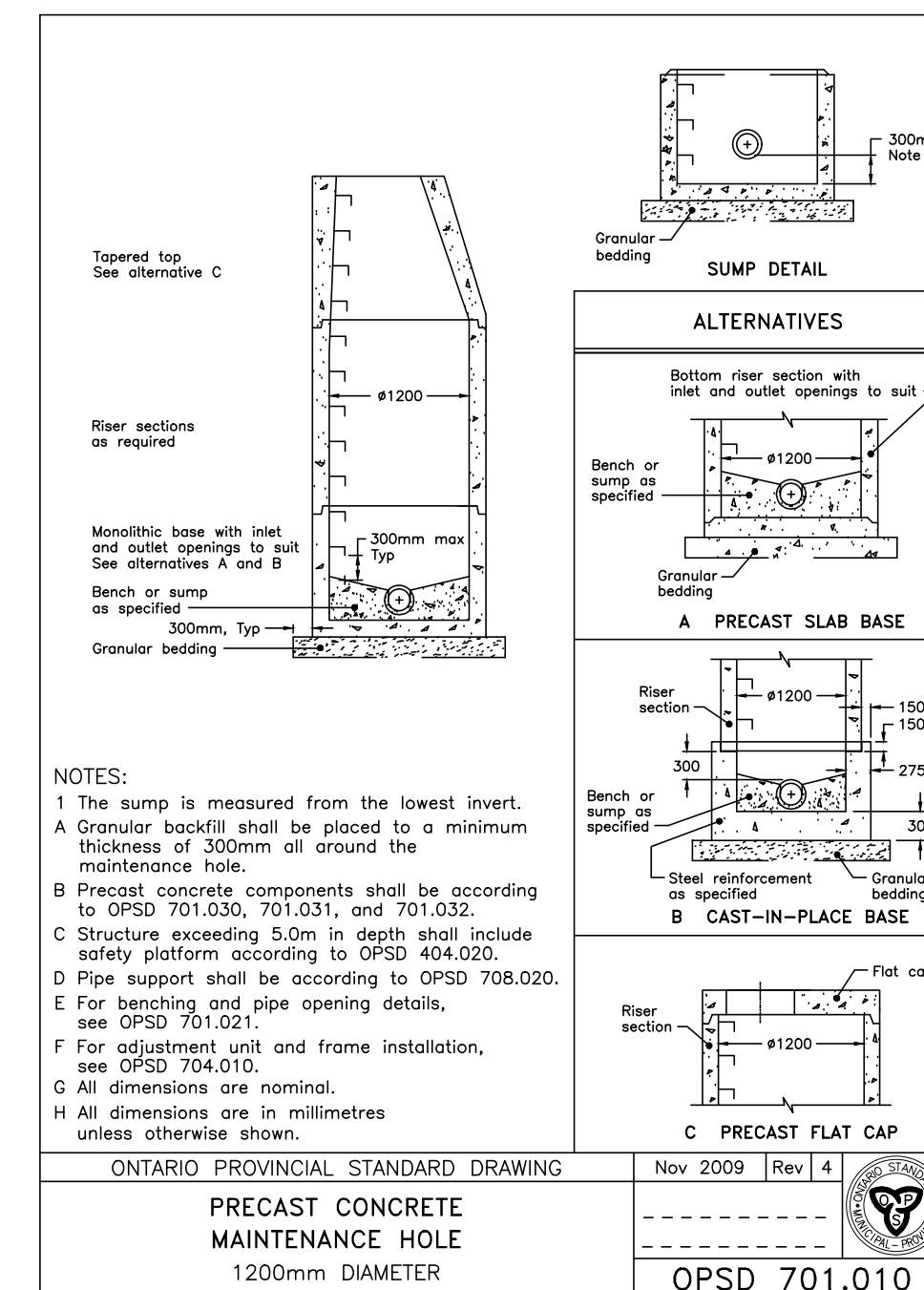

C:\Users\jvona\FEV0\AppData\Local\Temp\AcPublishing_23680\18037-BASE.dwg Layout:ND-1 Plotted Sep 08, 2021 @ 3:59pm by jvona @ PEARSON ENGINEERING LTD.

NO.	REVISION NOTE	DATE	BY
4.	REVISED AS PER CITY OF BARRIE COMMENTS	09/08/21	JPE
3.	MINOR REVISIONS/RESUBMISSION	04/07/21	PCO
2.	REVISED AS PER COMMENTS	04/21/20	PCO
1.	REVISED AS PER COMMENTS	10/02/19	PCO

BENCHMARK:

THE GEORGIAN APARTMENTS
290,294,298,&302 GEORGIAN DRIVE
BARRIE, ONTARIO

NOTES AND DETAILS

PEARSON ENGINEERING
PEARSONENG.COM PH. 705.719.4785

DESIGNED BY	PCO	HORIZ SCALE	PROJECT #	18037
DRAWN BY	MKW	VERT SCALE	DRAWING #	ND-1
CHECKED BY	GMP	DATE	REVISION #	4

SEPTEMBER 2018

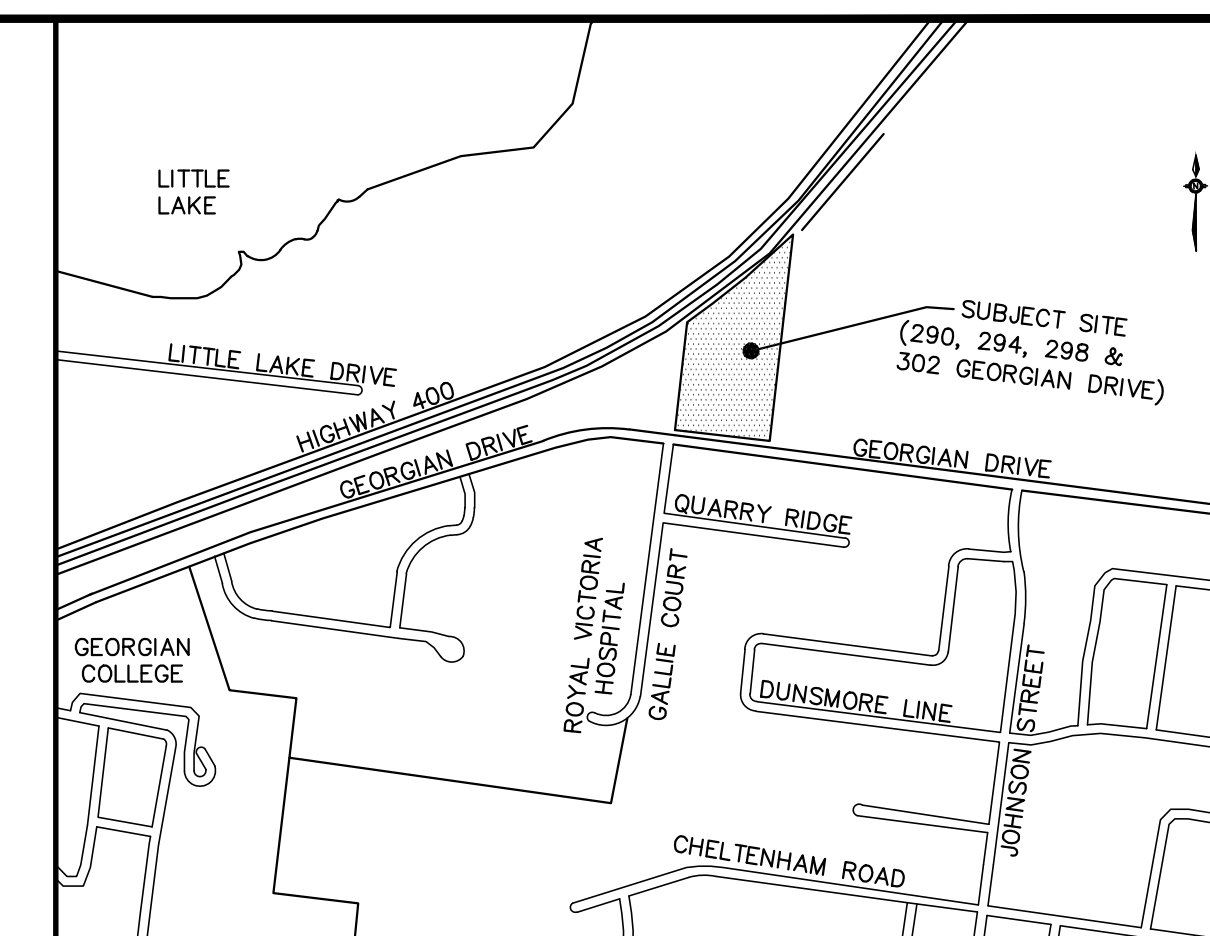
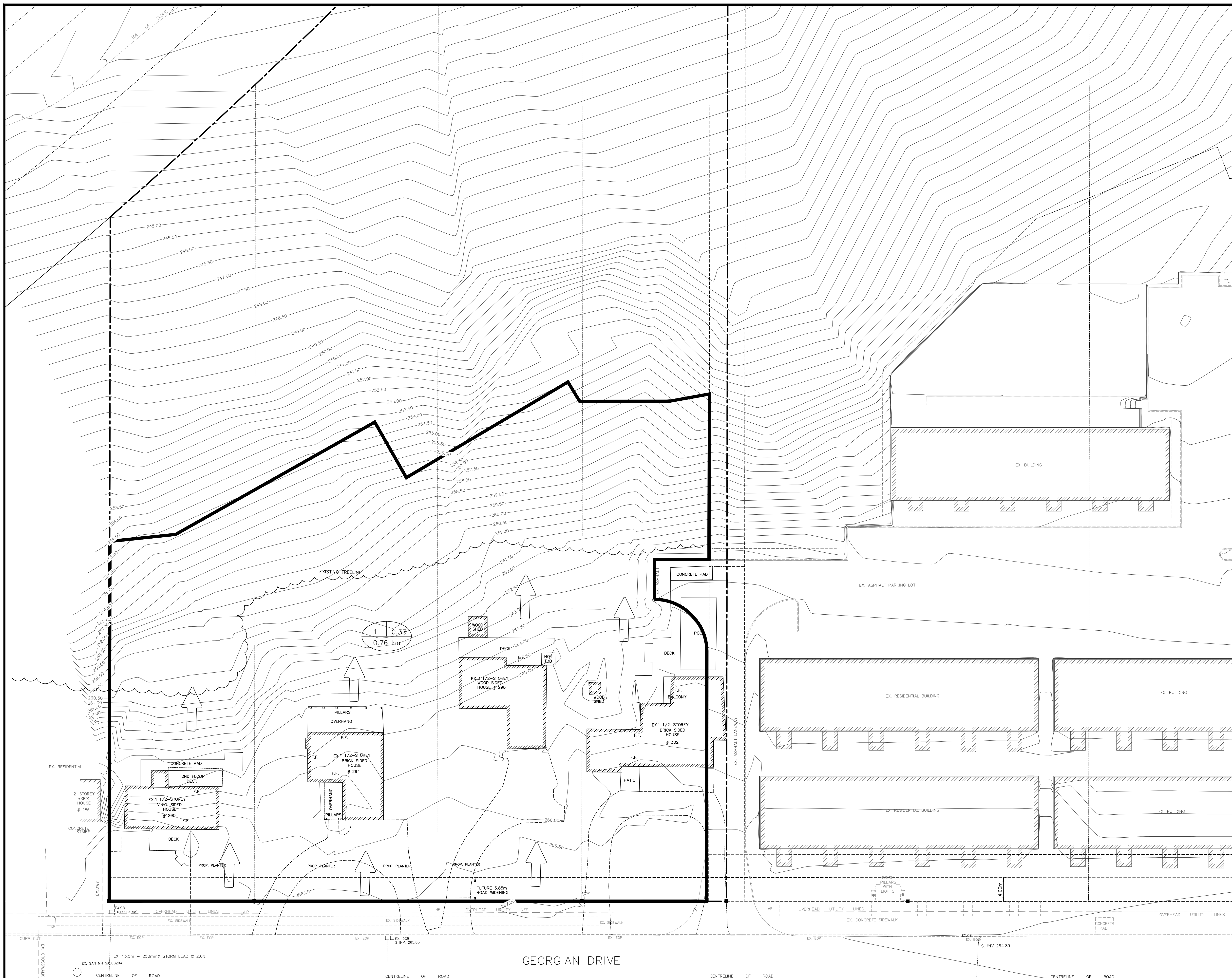

KEYMAP

LEGEND

- SAN MAINTENANCE HOLE
 - CATCH BASIN
 - ⊞ DOUBLE CATCH BASIN
 - ⊞ DOUBLE CATCH BASIN MAINTENANCE HOLE
 - ⊞ CATCH BASIN MAINTENANCE HOLE
 - STORM MAINTENANCE HOLE
 - x 386.96 PROPOSED ELEVATION
 - 386.96 EXISTING ELEVATION
 - 2% PROPOSED GRADE
 - SERVICE CAP
 - ◆ FIRE HYDRANT
 - WS WATER VALVE
 - CS CURB STOP
 - H.P. HYDRO POLE
 - ⊞ BELL PEDESTAL
 - ⊞ HYDRO TRANSFORMER
 - ⊞ LIGHT STANDARD
 - ⊞ WATER METER
 - BARRIER CURB
 - ➔ OVERLAND FLOW DIRECTION
-
- | | | | |
|----------------|---|------|--------------------|
| CATCHMENT AREA | 1 | 0.33 | RUNOFF COEFFICIENT |
| 0.76 ha | | AREA | |
- CATCHMENT BOUNDARY

C:\Users\jvona\FENVS\AppData\Local\Temp\AcPublish_23680\18037-BASE.dwg Layout:STM-1 Plotted Sep 08, 2021 @ 4:00pm by jvona @ PEARSON ENGINEERING LTD.

SITE BENCHMARK:
 LOCATED AT TOP OF HYDRANT SPINDLE ON THE SOUTH SIDE OF GEORGIAN DRIVE, ACROSS FROM SITE.
 ELEV. 267.46m

SURVEY:
 TOPOGRAPHIC SURVEY COMPLETED BY RUDY MAK SURVEYING LTD. AND ISSUED ON AUGUST 1, 2014.

NO.	REVISION NOTE	DATE	BY
4.	REVISED AS PER CITY OF BARRIE COMMENTS	09/08/21	JPE
3.	MINOR REVISIONS/RESUBMISSION	04/07/21	PCO
2.	REVISED AS PER COMMENTS	04/21/20	PCO
1.	REVISED AS PER COMMENTS	10/02/19	PCO

CONTROL MONUMENTS:

HORIZONTAL
 00119713803 – SOUTHWEST CORNER OF GEORGIAN DR & PENETANGUISHENE RD. EASTING 607787.028 NORTHING 4918904.790
 00119713804 – SOUTH SIDE OF GEORGIAN DR. ~110m WEST OF LARKIN DR. EASTING 607477.286 NORTHING 4918937.253

VERTICAL
 03120030002 – CAP – EASTING 606202 NORTHING 4918802
 RVH HELIPOINT AT WEST ENTRANCE. ELEV: 260.583
 00820038068 – CAP – EASTING 606084, NORTHING 4918831
 N.SIDE OF GEORGIAN DR. ~105m EAST OF GOVERNORS DR. ELEV: 258.425

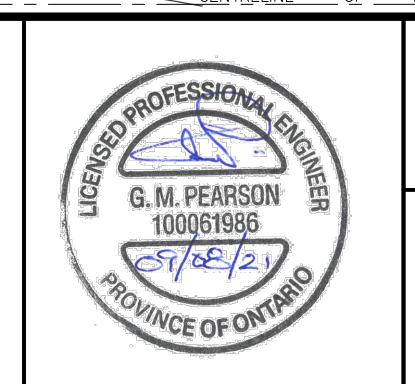

THE GEORGIAN APARTMENTS
 290,294,298,&302 GEORGIAN DRIVE
 BARRIE, ONTARIO

PRE-DEVELOPMENT STORM DRAINAGE PLAN



PEARSON ENGINEERING
 PEARSONENG.COM PH. 705.719.4785

DESIGNED BY	PCO	HORIZ SCALE	1:250	PROJECT #	18037
DRAWN BY	MKRW	VERT SCALE		DRAWING #	STM-1
CHECKED BY	GMP	DATE	SEPTEMBER 2018	REVISION #	4

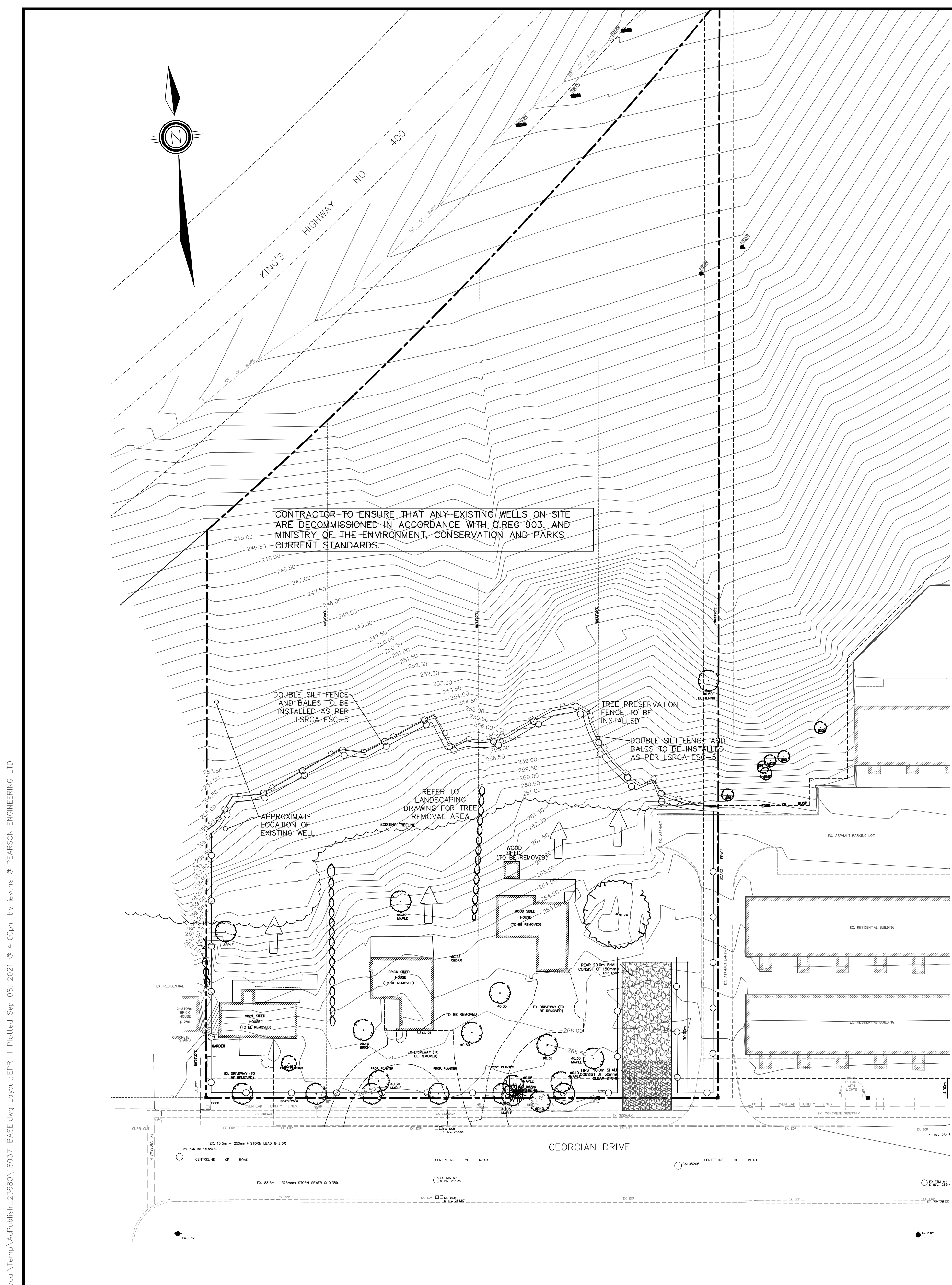

CONTRACTOR TO ENSURE THAT ANY EXISTING WELLS ON-SITE ARE DECOMMISSIONED IN ACCORDANCE WITH O. REG 903, AND MINISTRY OF THE ENVIRONMENT, CONSERVATION AND PARKS CURRENT STANDARDS.

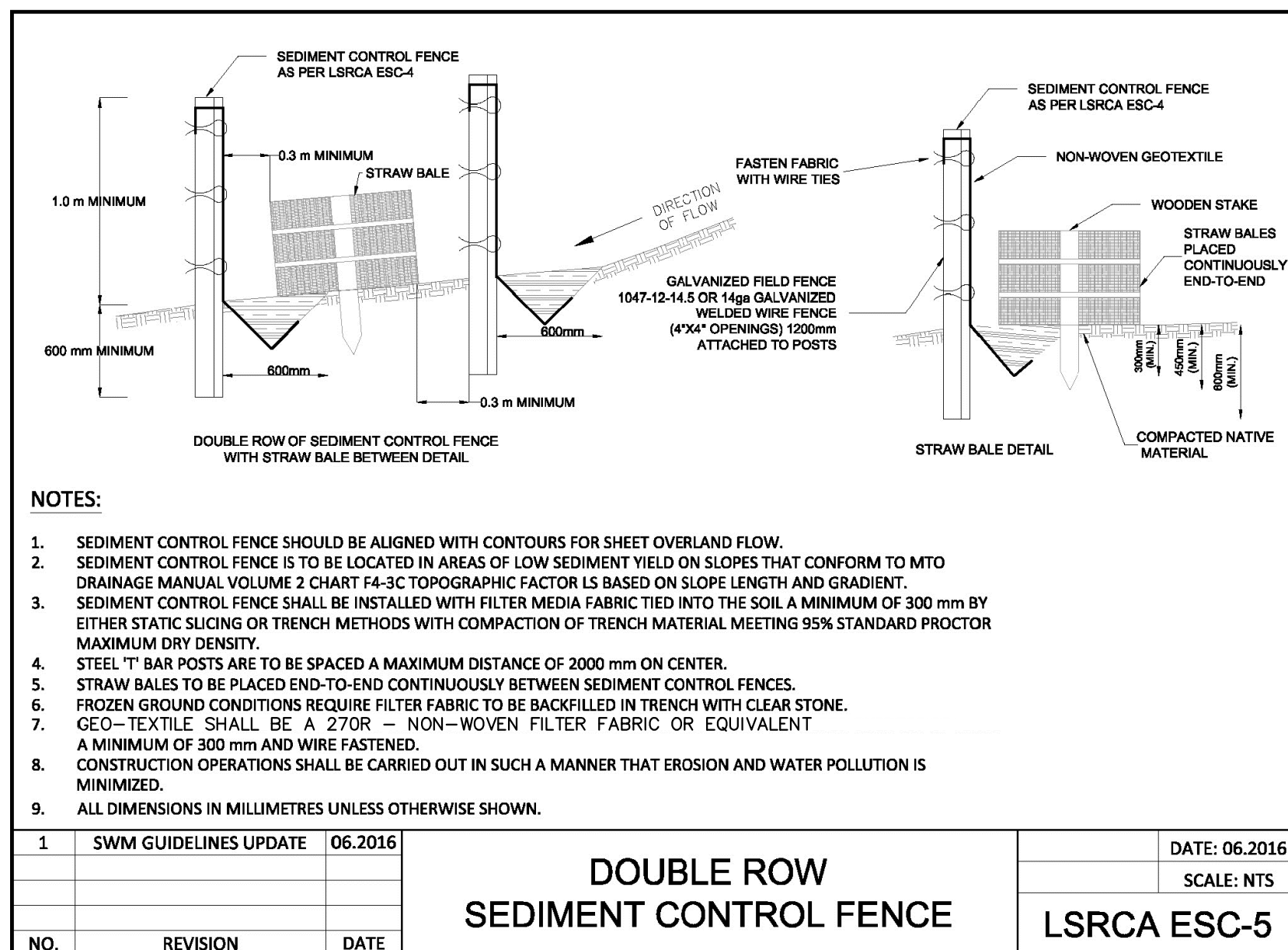
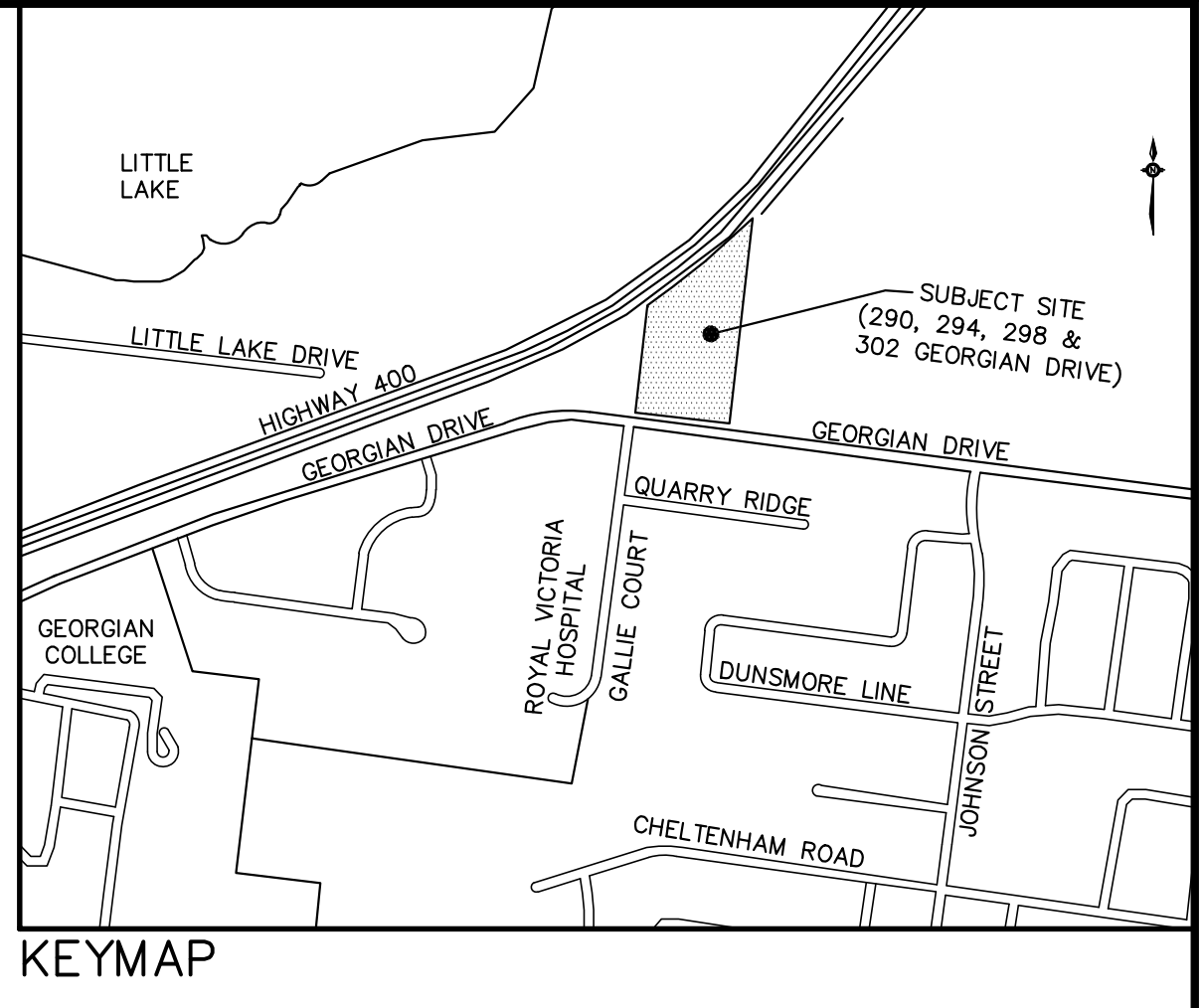
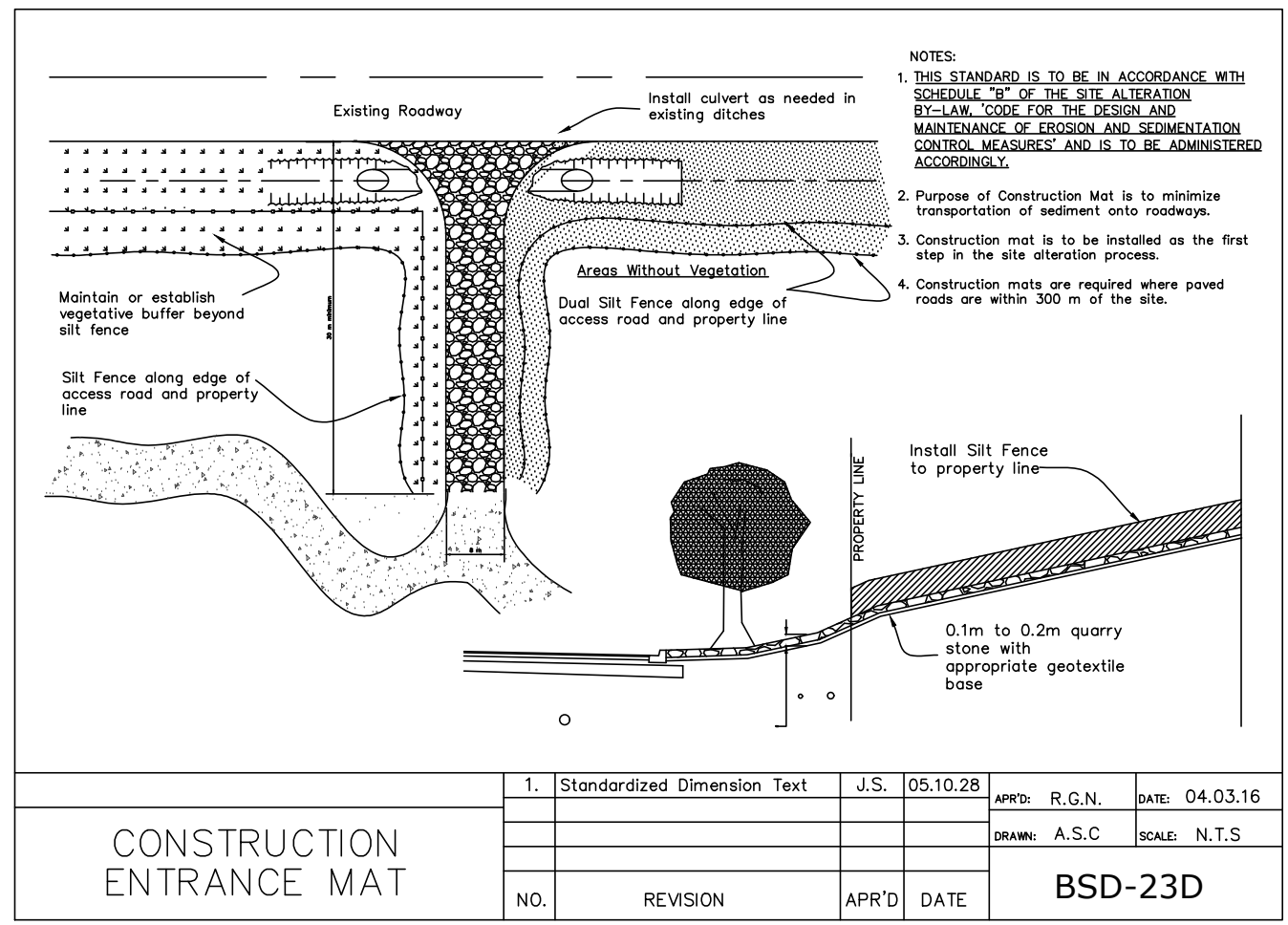

- LEGEND**
- SAN MAINTENANCE HOLE
 - CATCH BASIN
 - ▣ DOUBLE CATCH BASIN
 - ⊕ DOUBLE CATCH BASIN MAINTENANCE HOLE
 - ⊙ CATCH BASIN MAINTENANCE HOLE
 - STORM MAINTENANCE HOLE
 - x 386.96 PROPOSED ELEVATION
 - 386.96 EXISTING ELEVATION
 - 2% PROPOSED GRADE
 - SERVICE CAP
 - ◆ FIRE HYDRANT
 - ⊕ WATER VALVE
 - CS CURB STOP
 - H.P. HYDRO POLE
 - ⊗ BELL PEDESTAL
 - ⊠ HYDRO TRANSFORMER
 - ⊙ L.S. LIGHT STANDARD
 - ⊙ WATER METER
 - BARRIER CURB
 - SILT FENCE
 - ➔ OVERLAND FLOW DIRECTION

NOTES FOR SEDIMENT & EROSION CONTROL

- DISTURBED AREAS THAT HAVE FAILED TO HAVE STABLE GROUND COVER ESTABLISHED SHALL BE PROTECTED WITH A SILTATION CONTROL FENCE OR STRAW MULCH ETC. AND MAINTAINED BY THE CONTRACTOR UNTIL VEGETATION BECOMES ESTABLISHED IN THE SUBSEQUENT GROWING SEASON.
- SILT FENCE SHALL BE PUT IN PLACE PRIOR TO AND MAINTAINED DURING ALL GRADING. SILT FENCE TO BE INSPECTED PRIOR TO COMMENCEMENT OF EARTH GRADING ACTIVITIES. SILT FENCE TO BE INSPECTED AND REPAIRED OR REPLACED IF DAMAGED AS DIRECTED BY THE SITE ADMINISTRATOR. SILT CONTROLS TO BE INSPECTED ON A REGULAR BASIS AND AFTER EVERY RAIN EVENT. INSTALLATION SHALL BE TO THE MANUFACTURER'S SUGGESTED SPECIFICATIONS.
- THE CONTRACTOR SHALL BE PREPARED FOR UNEXPECTED CONDITIONS AND ACCORDINGLY HAVE STOCKPILED MATERIALS ON SITE FOR NECESSARY REPAIRS AS A RESULT OF FAILED OR INADEQUATE CONTROL MEASURES. ALL SEDIMENT AND EROSION CONTROL MEASURES SHALL BE INSPECTED AT LEAST ONCE A WEEK AND AFTER EVERY RAINFALL EVENT.
- MUD MATS AT ALL LOCATIONS WHERE CONSTRUCTION TRAFFIC ENTERS OR LEAVES THE SITE SHALL BE USED. MUD MATS TO CONSIST OF 500mm MIN 100mm TO 200mm CLEAR STONE HAVING DIMENSIONS 5.0m WIDE X 15.0m LONG.
- CONTRACTOR SHALL OBTAIN A CURRENT COPY AND BECOME FAMILIAR WITH OPSS 577, CONSTRUCTION SPECIFICATION FOR TEMPORARY EROSION AND SEDIMENT CONTROL MEASURES AS WELL AS ALL APPLICABLE MUNICIPAL STANDARDS.
- THE CONTRACTOR MAY CONSIDER ALTERNATIVE SEDIMENT AND EROSION CONTROL MEASURES. SUCH MEASURES SHOULD BE PRESENTED IN WRITING FOR APPROVAL OF THE SITE ADMINISTRATOR AND MUST BE APPROVED IN WRITING BY THE MUNICIPALITY AND CONSERVATION AUTHORITY.
- THE TOPS OF ALL FILTER FABRIC MUST BE A MINIMUM OF 1.0 METRES ABOVE THE GROUND LEVEL AND ATTACHED TO THE FENCE WITH A CONTINUOUS STEEL WIRE. ALTERNATIVELY, THE FILTER FABRIC MUST BE FOLDED OVER THE TOP OF THE FENCE AND ATTACHED TO THE FENCE WITH WIRE LOOPED THROUGH THE FABRIC ON BOTH SIDES OF THE FENCE. FILTER FABRIC IS TO BE TERRAFIX 270R OR EQUIVALENT.
- ALL DISTURBED GROUND LEFT INACTIVE SHALL BE STABILIZED BY SEEDING, SODDING, MULCHING, OR COVERING OR OTHER EQUIVALENT CONTROL MEASURES. THIS PERIOD OF INACTIVITY SHALL BE AT THE DISCRETION OF THE CITY OF BARRIE MANAGER OF ENGINEERING BUT SHALL NOT EXCEED THIRTY DAYS OR SUCH LONGER PERIOD DEEMED ADVISABLE BY THE CITY OF BARRIE MANAGER OF ENGINEERING.
- CONTRACTOR SHALL INSTALL AND MAINTAIN CATCHBASIN SEDIMENT BARRIERS THROUGHOUT THE SITE DURING ALL CONSTRUCTION ACTIVITIES IN ORDER TO TRAP SEDIMENT.

SEQUENCE OF CONSTRUCTION

- ENGINEER TO BE NOTIFIED PRIOR TO INITIATION OF ANY ON-SITE WORKS.
- SILT FENCE AND TO BE INSTALLED PRIOR TO THE COMMENCEMENT OF ANY WORKS ON-SITE.
- VEGETATION REMOVAL MAY COMMENCE AFTER ALL SILT FENCE IS INSTALLED AND APPROVED BY THE ENGINEER.
- COMMENCE WITH EARTH EXCAVATION AND SITE SERVICING (TO BE REMOVED FROM SITE).
- EROSION CONTROL MEASURES TO BE MAINTAINED AS DIRECTED BY THE ENGINEER DURING THE CONSTRUCTION PERIOD. ADDITIONAL CONTROL MEASURES MAY BE REQUIRED AT THE DISCRETION OF THE ENGINEER.
- ALL DISTURBED GROUND LEFT INACTIVE FOR MORE THAN 30 DAYS SHALL BE STABILIZED WITH SEED, SOD, MULCH OR OTHER ADEQUATE COVERING, AS INSTRUCTED BY THE ENGINEER.

I HAVE REVIEWED THE PLANS FOR THE CONSTRUCTION OF THE GEORGIAN APARTMENTS LOCATED AT 290, 294, 298 & 302 GEORGIAN DRIVE AND HAVE PREPARED THIS PLAN TO INDICATE THE COMPATIBILITY OF THE PROPOSAL TO EXISTING ADJACENT PROPERTIES AND MUNICIPAL SERVICES. IT IS MY BELIEF THAT ADHERENCE TO THE PROPOSED GRADES AS SHOWN WILL PRODUCE ADEQUATE SURFACE DRAINAGE AND PROPER FACILITY OF MUNICIPAL SERVICES WITHOUT ANY DETRIMENTAL EFFECT TO THE EXISTING DRAINAGE PATTERNS OR ADJACENT PROPERTIES.

SITE BENCHMARK:
 LOCATED AT TOP OF HYDRANT SPINDLE ON THE SOUTH SIDE OF GEORGIAN DRIVE, ACROSS FROM SITE.
 ELEV. 267.46m

SURVEY:
 TOPOGRAPHIC SURVEY COMPLETED BY RUDY MAK SURVEYING LTD. AND ISSUED ON AUGUST 1, 2014.

NO.	REVISION NOTE	DATE	BY
4.	REVISED AS PER CITY OF BARRIE COMMENTS	09/08/21	JPE
3.	MINOR REVISIONS/RESUBMISSION	04/07/21	PCO
2.	REVISED AS PER COMMENTS	04/21/20	PCO
1.	REVISED AS PER COMMENTS	10/02/19	PCO

CONTROL MONUMENTS:
HORIZONTAL
 00119713803 - SOUTHWEST CORNER OF GEORGIAN DR & PENETANGUISHENE RD. EASTING 607787.028 NORTHING 4918904.790
 00119713804 - SOUTH SIDE OF GEORGIAN DR. ~110m WEST OF LARKIN DR. EASTING 607477.286 NORTHING 4918937.253
VERTICAL
 03120030002 - CAP - EASTING 606202 NORTHING 4918802
 RVH HELIPOINT AT WEST ENTRANCE. ELEV: 260.583
 00620038068 - CAP - EASTING 606084, NORTHING 4918831
 N.SIDE OF GEORGIAN DR. ~105m EAST OF GOVERNORS DR. ELEV: 258.425

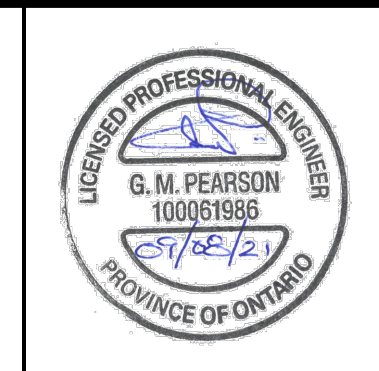

THE GEORGIAN APARTMENTS
 290, 294, 298, & 302 GEORGIAN DRIVE
 BARRIE, ONTARIO

EROSION PROTECTION AND
 REMOVALS PLAN

PEARSON ENGINEERING
 PEARSONENG.COM PH. 705.719.4785

DESIGNED BY: PCO HORIZ SCALE: 1:250 PROJECT #: 18037
 DRAWN BY: MKRV VERT SCALE: DRAWING #: EPR-1
 CHECKED BY: GMP DATE: SEPTEMBER 2018 REVISION #: 4